

Profiles for Industry

Industrie profile



INTRODUCTION	1
MANAGEMENT STRUCTURES	2
MILESTONES	3
ELASTOMERS AND THEIR CHARACTERISTICS	4
L - PROFILES	5
T - PROFILES	9
U - PROFILES	13
ROUND CORDS	20
TUBES WITHOUT PLIES	20
SQUARE PROFILES	20
ROUND PROFILES	21
RECTANGULAR PROFILES	25
FLAT PROFILES	31
DOOR PROFILES	34
WINDOW PROFILES	37
AUTOMOTIVE PROFILES	44
WINDOW PROFILES - MEDIUM	48
OTHERS PROFILES	50

EINLEITUNG	1
ORGANISATIONSSCHEMA	2
ÜBERSICHT	3
ELASTOMERE UND CHARAKTERISTIKEN	4
L-PROFILE	5
T-PROFILE	9
U-PROFILE	13
RUNDSCHNÜRE	20
SCHLÄUCHE	20
RECHTECKPROFILE	20
RUNDPROFILE	21
VIERKANTPROFILE	25
FLACHPROFILE	31
DICHTUNGSPROFILE FÜR TÜREN	34
DICHTUNGSPROFILE FÜR FENSTER	37
PROFILE FÜR DEN FAHRZEUGBAU	44
DICHTUNGSPROFILE FÜR FENSTER - MITTELDICHTUNG	48
SONDERPROFILE	50

Owing to its characteristics and favourable prices rubber is widely used for flexible sealing as well as muffling of vibrations and isolation. Profiles balance tolerances, connect and reinforce. Despite wide choice of synthetic materials and due to its characteristics and favourable prices, rubber is still practically irreplaceable.

Profiles for industry which are made of solid rubber are the most varied and extensive group of our production programme as far as application range and number are concerned. In addition to these profiles our production programme comprises also industrial sponge profiles, profiles for window and door tightening, and ribbed profiles for conveyor belts.

Special catalogues are available for all listed products.

For different applications we have developed a number of quality rubber compounds which are noted for long service life and are resistant to mechanical impacts, chemicals and temperatures. We are able to adjust compound composition to your requirements or special standards.

In February 1998 the Bureau Veritas Quality International certified the development, the production and the sales of rubber profiles according to the BS EN ISO 9001 quality standard. In December 2000 we were certified with the ISO 9001 standard. In 2001 Savatech obtained the environmental certificate SIST ISO 14001 and in 2004 OHSAS 18001, which verifies that Savatech operates in accordance with the occupational health and safety standards.

We laid up a list of industrial profiles by shape and purpose



Sava hat sich in den letzten 20 Jahren zu einem der führenden Anbieter von Gummiprofilen in Europa entwickelt. Mit modernster Technologie und stetig gewachsenem Know-how sind wir heute in der Lage, fast allen Bedarfsfällen im Bereich Gummiprofile gerecht zu werden.

Industrieprofile aus Vollgummi stellen bei uns, in Hinsicht auf Verwendbarkeit und Anzahl, die vielfältigste und umfangreichste Produktgruppe dar. Weitere Produktgruppen, wie Gummiprofile für Fenster- und Türsysteme, Moosgummiprofile, Rippenprofile für Fördergurte komplettieren unser Fertigungsprogramm.

Bitte fordern Sie bei Bedarf die entsprechenden Spezialkataloge an.

Entsprechend den verschiedensten Einsatzmöglichkeiten haben wir Gummiquitäten entwickelt, die gegen mechanische, chemische und wärmetechnische Belastungen beständig sind und sich durch eine hohe Lebensdauer auszeichnen.

Im Falle spezieller Normen oder Forderungen können die Mischungen ihren Wünschen angepaßt werden.

Im Februar 1998 wurden die Entwicklung, die Produktion und der Verkauf von Gummiprofilen gemäß BS EN ISO 9001 vom Bureau Veritas Quality International zertifiziert, und im Dezember 2000 wurden die Gummiprofile auch gemäß ISO 9001 zertifiziert. Im Jahre 2001 erhielt Savatech das Umweltzertifikat ISO 14001. Das im Jahre 2004 erteilte Zertifikat OHSAS 18001 bestätigt, dass die Tätigkeit der Savatech im Einklang mit den Arbeitsschutznormen verläuft.

Im weiteren Verlauf des Katalogs sind alle Industrieprofile nach Form bzw. Einsatzzweck unterteilt.

SAVA, d.d. - HOLDING

RUBBER MANUFACTURING TEHNISCHE GUMMIPRODUKTE	TOURISM TOURISMUS	REAL ESTATE IMMOBILIEN	OTHER OPERATIONS ÜBRIGE GESCHÄFTE	INVESTMENT FINANCE INVESTITIONSFINANZEN
SAVATECH, d.o.o., Kranj	GOLF & KAMP BLEED, d.d., Bled - 91 %	SAVA IP, d.o.o., Ljubljana	SAVA MEDICAL AND SERVICES d.o.o., Kranj	Investments in Future Projects Investitionen in Zukunftsträchtige Projekte
SAVA ROL, d.o.o., Zagreb 76 %	GRAND HOTEL TOPLICE, d.o.o., Bled - 99,7 %	▲ IP NOVA d.o.o., Ljubljana - 100 %	BIOOL, d.o.o., Kranj	
SAVA-SCHÄFER, d.o.o., Kranj - 50 %	G & P HOTELI BLEED d.o.o., Bled - 95,8 %	▲ IP NOVA A d.o.o., Ljubljana - 100 %	GEA SOL Int, d.o.o., Kranj	Financial Investments Finanzanlagen
SAVA-GTI, d.o.o., Ptuj	TERME 3000, d.d., Moravske toplice - 97,6 %	▲ SAVA IPN d.o.o., Ljubljana - 100 %	ENERGETIKA SAVA d.o.o., Kranj	• Investments in associates Teilhaber Investments
Foreign Trade Network Niederlassungen	▲ TERME LENDAVA, d.o.o., Lendava - 93 %	▲ PC AG d.o.o., Velenje - 50 %	▲ ENERGETIKA ČRNOMELJ d.o.o., Kranj	- Gorenjska banka d.d., Kranj - 41,4 % - Merkur d.d., Kranj - 20 % - Limb d.o.o., Ptuj - 37,5 % - Job d.d., Maribor - 27 %
SAVA TRADE, GmbH, Munich	▲ TERME RADENCI, d.o.o., Radenci - 100 %	▲ SAVA IMG d.o.o., Poreč - 50 %		• Other financial investments Übrige Finanzielle Investments
SAVA TRADE, Sp.z.o.o., Warsaw	TERME PTUJ, d.o.o., Ptuj	SAVA NOVA d.o.o., Zagreb		
SAVA TRADE, s.r.o., Prague				
SAVATECH TRADE, Ltd, London				
SAVA TRADE d.o.o., Split Port Orange - 70 %				
SAVATECH CORP., Port Orange - 95 %				

Historical Background

SAVA has been producing industrial rubber products and tyres ever since 1920 when the company ATLANTA had been established in Kranj.

The Profiles Programme

- 1970 - start of rubber profiles production in Sava Kranj
- 1978 - start up of the 1st LCM line for rubber profiles production
- 1995 - establishing own sales company in Germany Sava Trade GmbH
- 1997 - reorganisation of the profiles programme
- 1998 - obtaining BS EN ISO 9001 certification
- 1998 - start up of a new, 5th line for profiles production
- 1999 - completing the programme with sponge rubber profiles
- 2000 - Obtaining the SIST ISO 14001 certificate
- 2000 - Start-up of a new LCM line
- 2004 - Start-up of a new, fifth, LCM line, the tenth rubber profile manufacturing line

SAVA d.d. Aktiengesellschaft

SAVA produziert Gummiprodukte und Reifen schon seit 1920, als die Firma ATLANTA in Kranj gegründet wurde.

Geschäftsbereich Gummiprofile

- 1970 - Beginn der Produktion von Gummiprofilen bei Sava
- 1978 - Inbetriebnahme der ersten LCM-Produktionslinie für die Herstellung von Gummiprofilen
- 1995 - Gründung eines Vertriebsunternehmens in Deutschland Sava Trade GmbH
- 1997 - Reorganisation von Gummiprofilen
- 1998 - Zertifizierung gemäß BS EN ISO 9001
- 1998 - Inbetriebnahme der fünften Produktionslinie
- 1999 - Programmerweiterung durch den Produktbereich Moosgummiprofile
- 2000 - Zertifizierung gemäß SIST ISO 14001 Norm
- 2000 - Inbetriebnahme einer neuen LCM Linie
- 2004 - Inbetriebnahme einer neuen, fünften, LCM Linie, zehnter Linie für Herstellung von Gummiprofilen

Elastomers and their characteristics

Elastomere und Charakteristiken

synthetic rubber / compound types Synthesekautschuk / Mischungstyp	EPDM ethylene-propylenediene Äthylen Propylen-Dien	NBR acrylonitril-butadiene Akrylonitril-Butadien	CR polychloroprene Polychloro-pren	SBR styrenbutadiene Styren-Butadien
Hardness range [ShoreA] (± 5) ⁽¹⁾ Härtebereich [ShoreA] (± 5) ⁽¹⁾	45 - 95	60 - 70	40 - 63	45 - 60
Colour Farbe	black, grey, brown, beige, white schwarz, grau, braun, beige, weiß	black schwarz	black schwarz	black schwarz
Tensile strength [N/mm ²] Zerreißfestigkeit [N/mm ²]	6 - 13	4 - 14	5 - 15	4 - 15
Oil resistance Ölbeständigkeit	low gering	very good sehr gut	good gut	low gering
Petrol resistance Kraftstoffbeständigkeit	low gering	medium to very good ⁽²⁾ mittel bis sehr gut ⁽²⁾	medium to good ⁽²⁾ mittel bis gut ⁽²⁾	low gering
Temperature stability °C ⁽³⁾ for shorter periods °C ⁽³⁾ Temperaturbeständigkeit °C ⁽³⁾ kurzdauernd °C ⁽³⁾	-30 ÷ 110 150	-20 ÷ 100 120	-20 ÷ 80 100	-20 ÷ 80 100
Solvent resistance ⁽⁴⁾ Lösungsmittelbeständigkeit ⁽⁴⁾	good gut	good gut	good gut	satisfactory befriedigend
Lye resistance ⁽⁵⁾ Beständigkeit gegen Laugen ⁽⁵⁾	good gut	good gut	good gut	good gut
Ozone resistance Ozonbeständigkeit	excellent ausgezeichnet	low gering	very good sehr gut	low gering
General climate resistance Allgemeine Witterungsbeständigkeit	excellent ausgezeichnet	good gut	very good sehr gut	good gut

(1) Valid for IRHD product. (2) Depends on the type of petrol. (3) These are borderline values which, depending on the composition of the compound, can vary. If used permanently in such borderline areas, this can lead to a change in the physical values. For such extreme application it is advisable to use special elastomer compounds.

(4) Depends on the type of acid. Compound compositions require adjustments. (5) Depends on the type of lye.

(1) Gilt für IRHD Produkt. (2) Hängt vom Kraftstofftyp ab. (3) Es handelt sich um Grenzwerte, die je nach Zusammensetzung der Mischung schwanken können.

Der Dauereinsatz in den Grenzbereichen bringt eine Änderung der physikalischen Werte mit sich. Für extreme Beanspruchungen sind besondere Mischungen erforderlich.

(4) Es hängt vom Säuretyp ab. Die Mischungstypen können dementsprechend angepaßt werden. (5) Es hängt vom Laugentyp ab.

MARKING

The last two places by the name of product denote:

E=EPDM, C=NBR, D=CR, B=SBR

4=45° ShA

5=50° ShA

6=60° ShA

7=70° ShA

8=80° ShA

tolerances +/-5°

KENNZEICHNUNG

Die letzten beiden Stellen in der Benennung enthalten folgende Codierung: E=EPDM, C=NBR, D=CR, B=SBR

4=45° ShA

5=50° ShA

6=60° ShA

7=70° ShA

8=80° ShA

Toleranzen +/-5°

DIMENSIONAL TOLERANCES

If no reference is made in drawings to measurement tolerances, then the E2 class of ISO 3302-1 standard applies (medium accuracy):

nominal measure (mm) Nennmaß (mm)	up to bis	over-up to über-bis	over-up to über-bis	over-up to über-bis	over-up to über-bis	over-up to über-bis	over-up to über-bis	over-up to über-bis	over-up to über-bis	over-up to über-bis
		1,5	1,5 - 2,5	2,5 - 4	4 - 6,3	6,3 - 10	10 - 16	16 - 25	25 - 40	40 - 63
permitted tole. ± Zulässige Abweichung ±	0,25	0,35	0,40	0,50	0,70	0,80	1,00	1,30	1,60	2,00

TOLERANZEN

Falls in der Zeichnungen nicht anders angegeben, gilt ISO 3302-1, E2 (mittlere Genauigkeit):

PACKING

- Different lengths (100, 200, 300, 400, 500 m) on cardboard spools, in cardboard boxes
- As required by customers.

ORDERING

- Selecting the required profiles from our catalogues;
- Providing drawings in scales 10:1 or 5:1, plus required quality, hardness and operating conditions;
- Providing samples;
- Type of packaging;
- Approximate annual usage.

VERPACKUNG

- Verschiedene Fixlängen/Endlos (100, 200, 300, 400, 500 m) auf Pappspulen, in Karton verpackt;
- Verschiedene Fixlängen in Karton verpackt;
- Auf Kundenwunsch.

BESTELLUNG

- Nach bestehenden Katalogen;
- Sonderprofile nach Zeichnung im Masstab 10:1 od. 5:1, mit Angabe der Qualität, Härte und Einsatzbedingungen;
- Nach Mustern;
- Mit Angabe der Verpackungsweise;
- Mit Angabe der ungefähren Jahresmenge.

01 001 E7

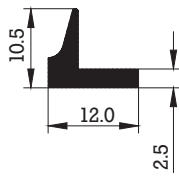

1:1

01 014 D7

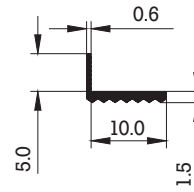

1:1

01 019 A7

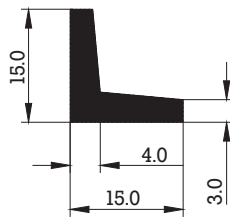

1:1

01 031 E7

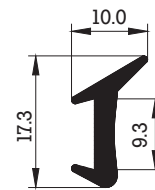

1:1

01 030 D6

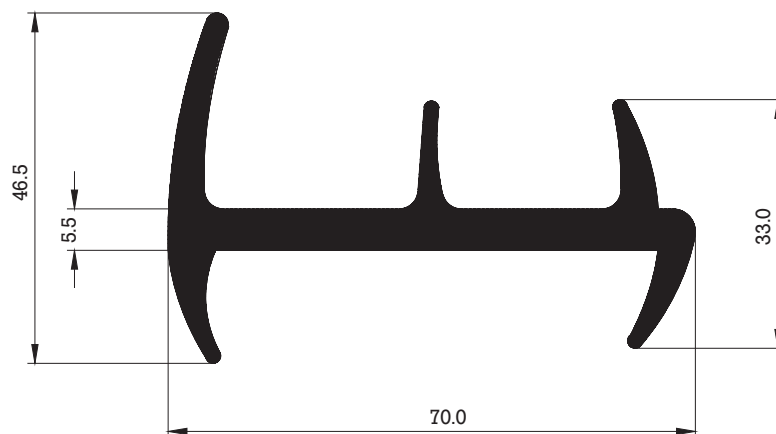

1:1

01 035 E6

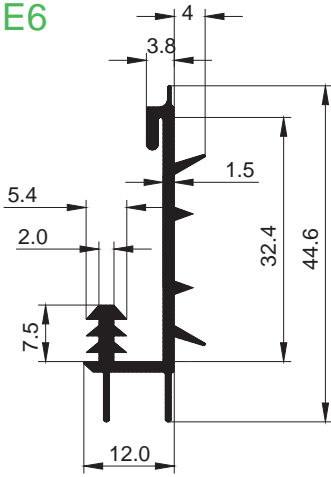

1:1

01 044 E7

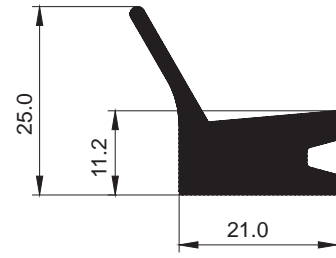

1:1

01 047 E7

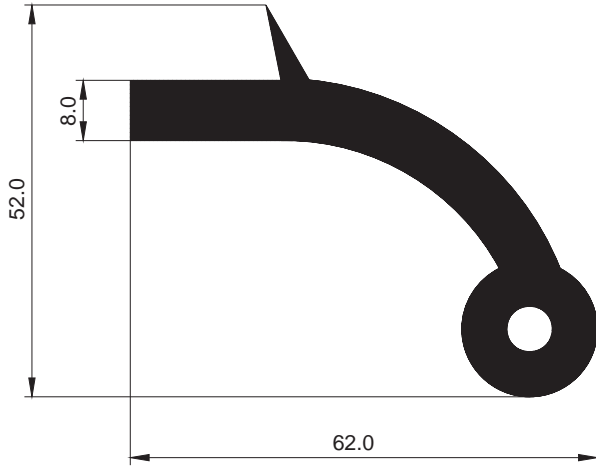

1:1

01 059 E7

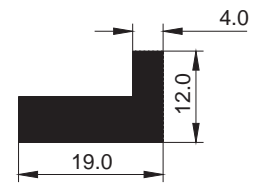

1:1

01 075 E6

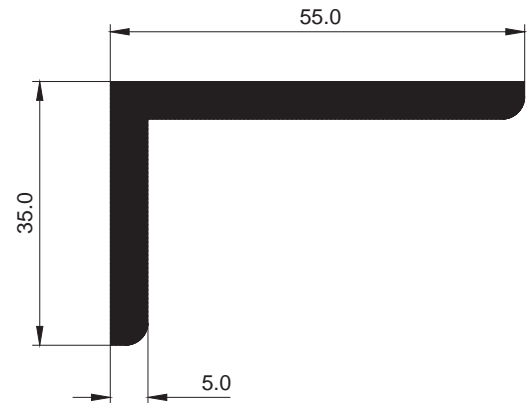

1:1

01 078 E5

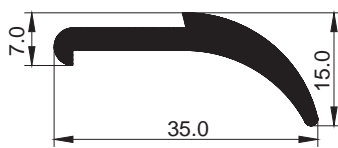

1:1

01 080 C7

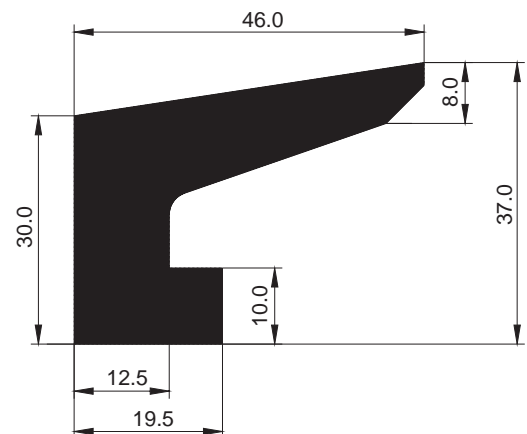

1:1

01 079 E7

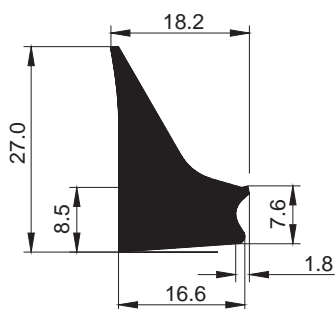

1:1

01 081 C7

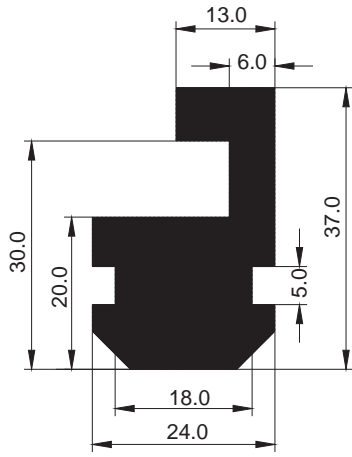

1:1

01 082 C7

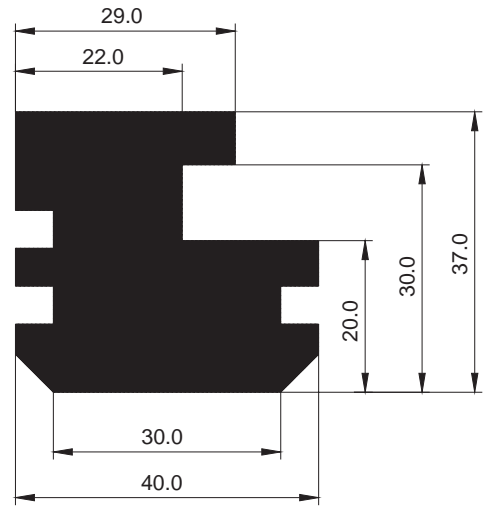

1:1

01 083 D6

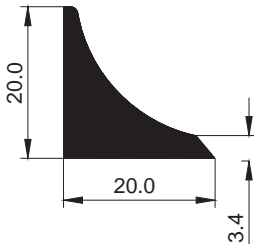

1:1

01 084 E7

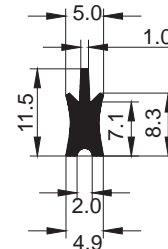

1:1

01 141 C7

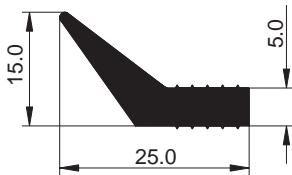

1:1

01 142 E6

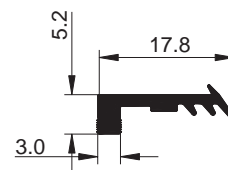

1:1

02 182 E7

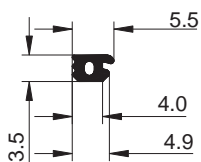

1:1

02 084 C7

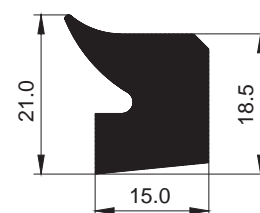

1:1

02 086 C7

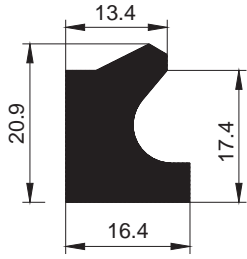

1:1

02 095 E7

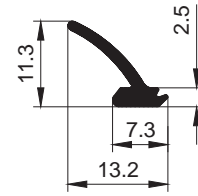

1:1

02 082 C7

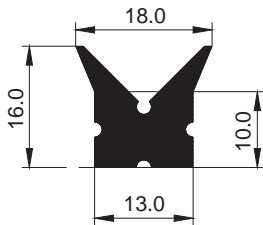

1:1

02 190 E6

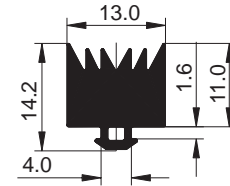

1:1

07 046 E7

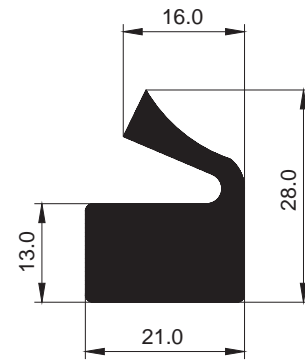

1:1

05 047 E8

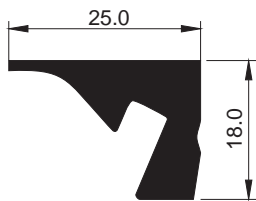

1:1

15 006 D6

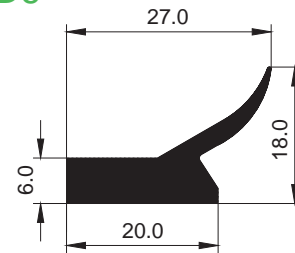

1:1

19 028 E7

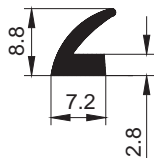

1:1

20 017 D6

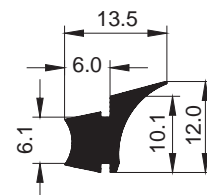

1:1

01 138 E5

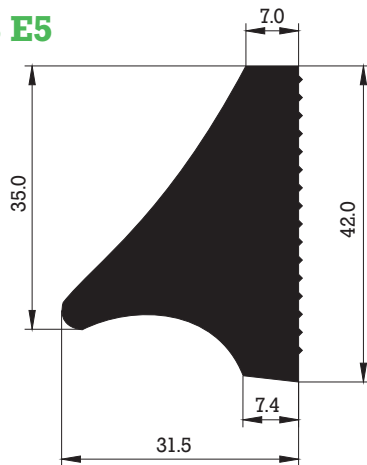

1:1

02 001 E5

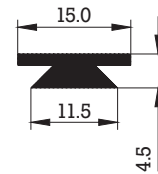

1:1

02 012 E6

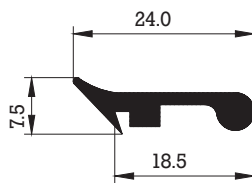

1:1

02 016 A4

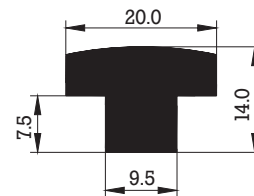

1:1

02 050 E6

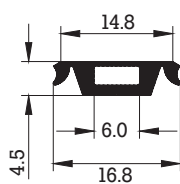

1:1

02 056 E7

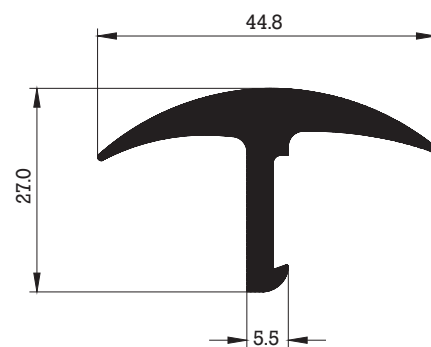

1:1

02 057 E7

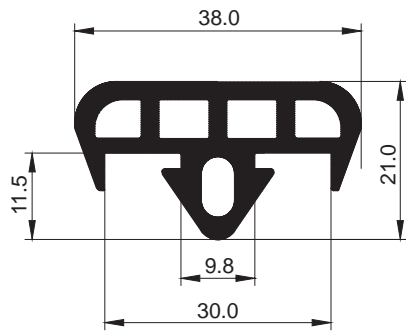

1:1

02 059 E6

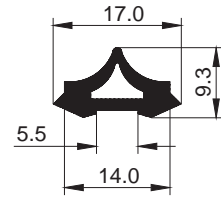

1:1

02 061 E6

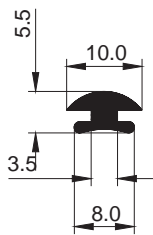

1:1

02 074 E6

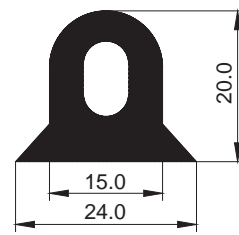

1:1

02 077 E5

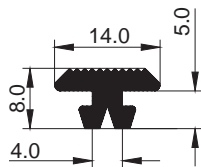

1:1

02 078 E6

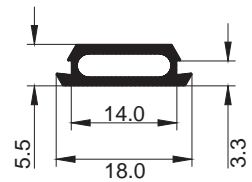

1:1

02 085 E6

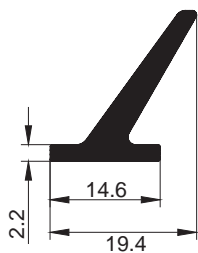

1:1

02 087 E8

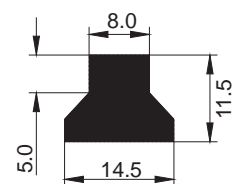

1:1

02 090 E7

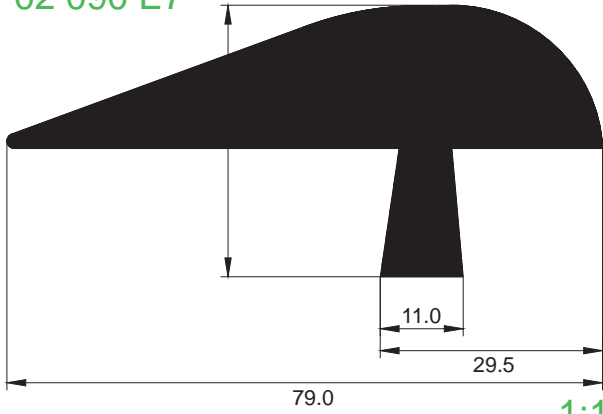

1:1

02 092 E5

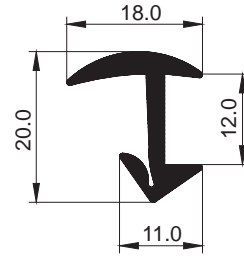

1:1

02 094 E7

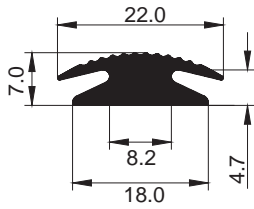

1:1

02 101 E6

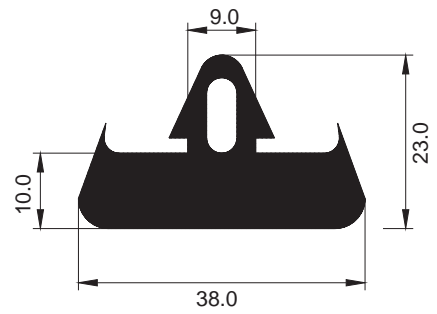

1:1

02 103 E7

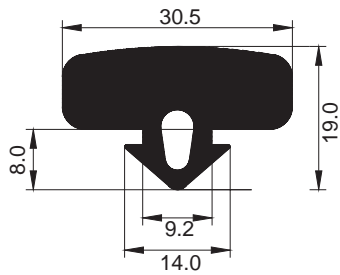

1:1

02 105 E6

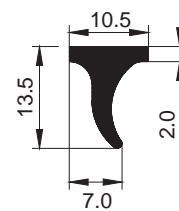

1:1

02 131 E6

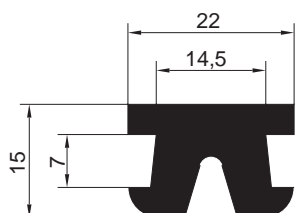

1:1

02 192 E7

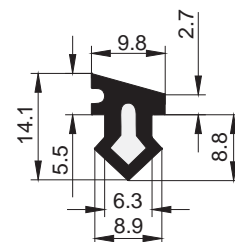

1:1

05 008 D6

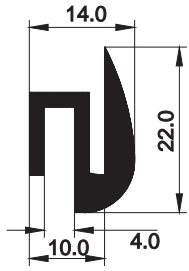

1:1

05 037 E7

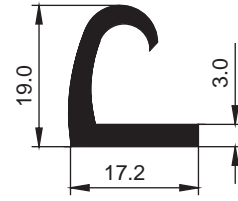

1:1

13 010 E7

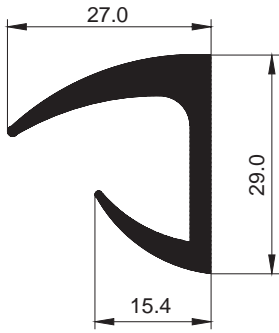

1:1

13 013 E5

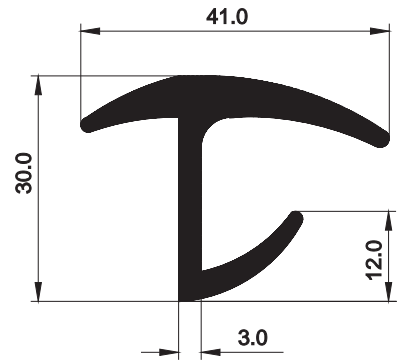

1:1

22 024 B7

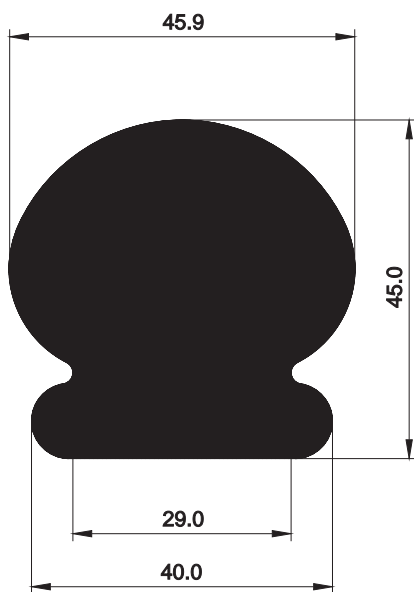

1:1

21 002 A7

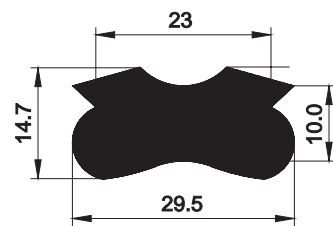

1:1

22 040 A5

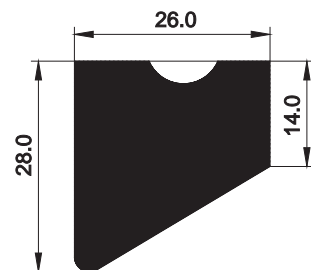

1:1

02 192 E7

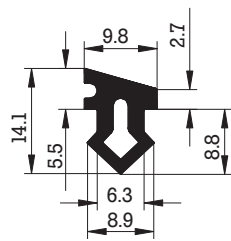

1:1

03 001 E7

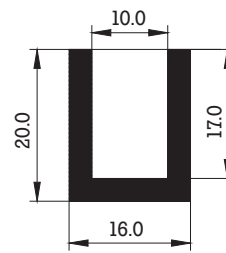

1:1

03 009 D6

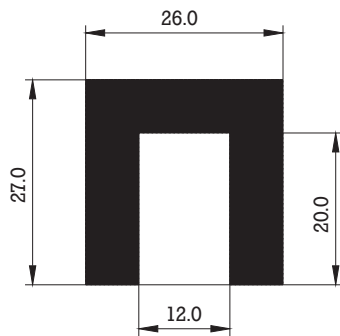

1:1

03 010 D6

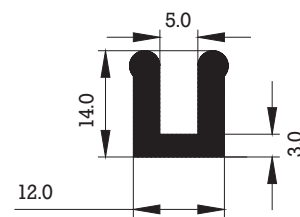

1:1

03 011 D6

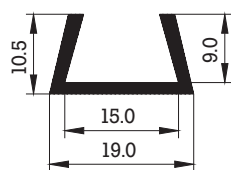

1:1

03 022 D6

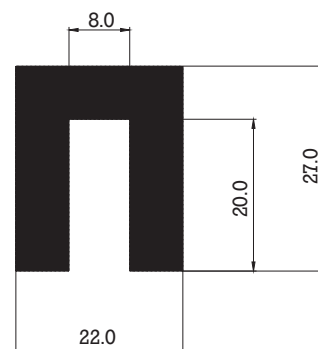

1:1

03 044 E6

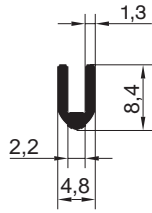

1:1

03 027 E7

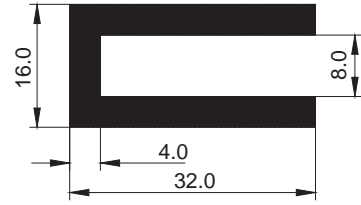

1:1

03 028 E6

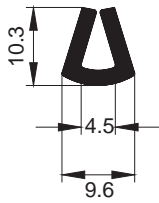

1:1

03 029 E6

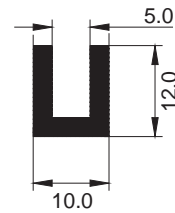

1:1

03 030 E6

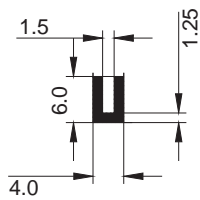

1:1

03 031 E6

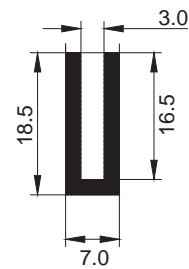

1:1

03 043 E8

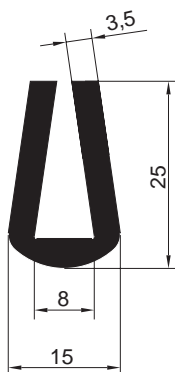

1:1

04 001 E7

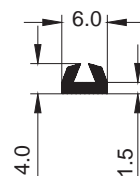

1:1

04 005 E7

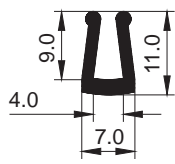

1:1

04 006 A7

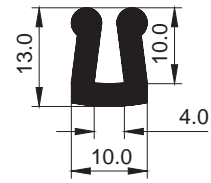

1:1

04 008 A7

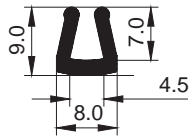

1:1

04 012 D4

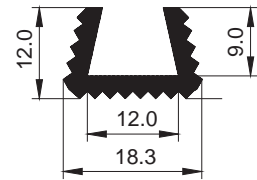

1:1

04 015 E7

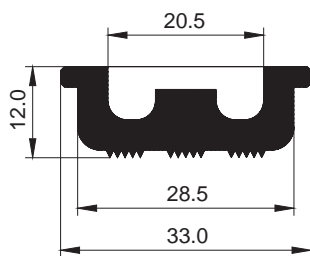

1:1

04 016 E7

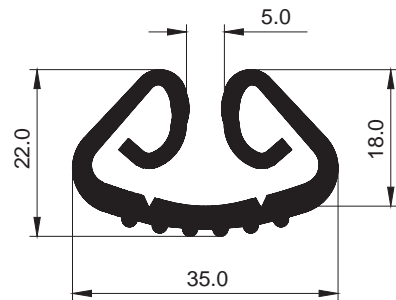

1:1

04 020 D4

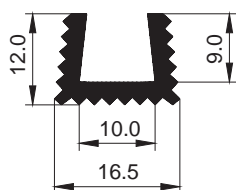

1:1

04 022 E5

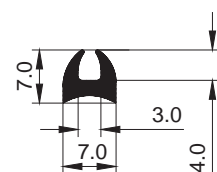

1:1

05 003 A7

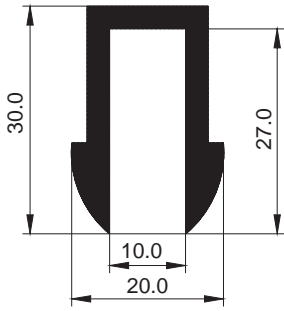

1:1

05 011 E7

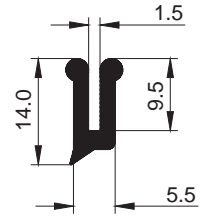

1:1

05 014 D6

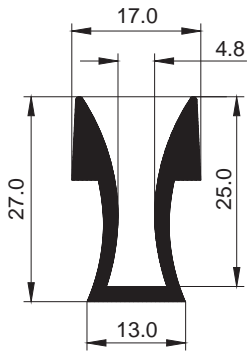

1:1

05 015 E7

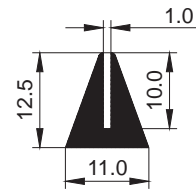

1:1

05 035 E7

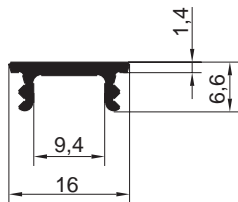

1:1

05 032 E7

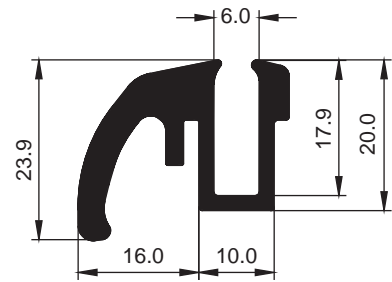

1:1

05 053 E6

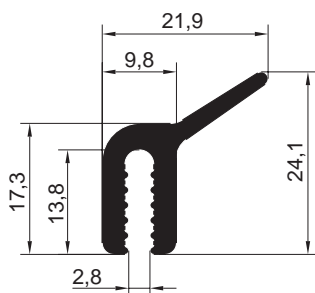

1:1

05 048 E8

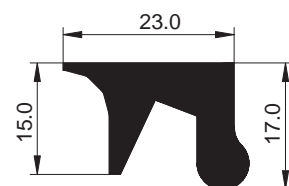

1:1

06 002 A4

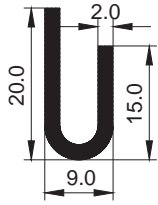

1:1

06 003 A7

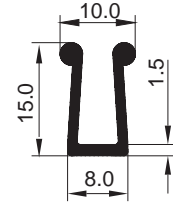

1:1

06 004 E7

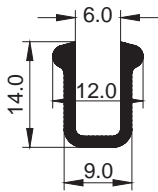

1:1

06 006 E7

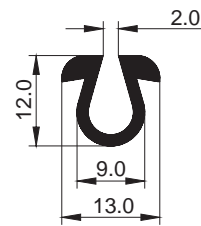

1:1

06 008 D5

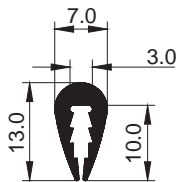

1:1

06 029 D8

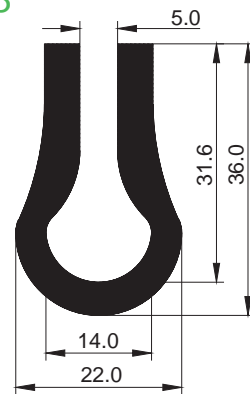

1:1

06 104 E7

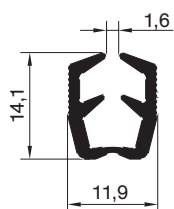

1:1

06 035 E6

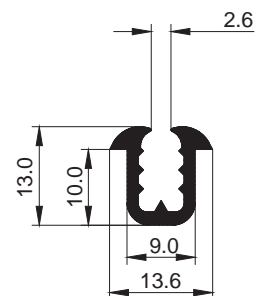

1:1

06 038 E7

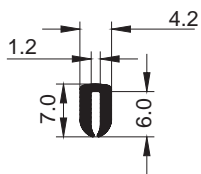

1:1

06 039 E8

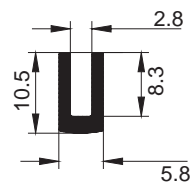

1:1

06 040 D4

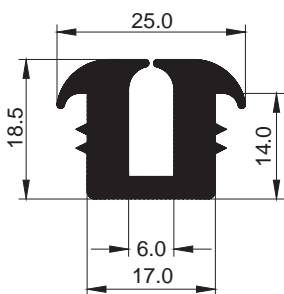

1:1

06 041 D4

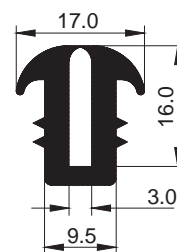

1:1

06 043 E5

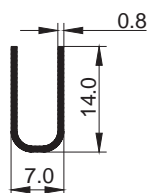

1:1

06 045 E5

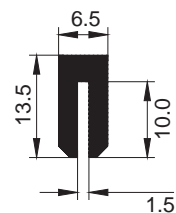

1:1

06 046 E7

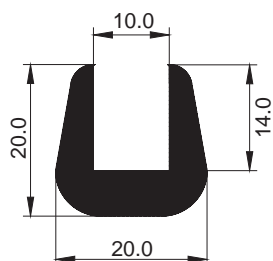

1:1

06 047 E6

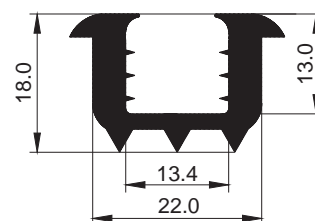

1:1

06 049 E6

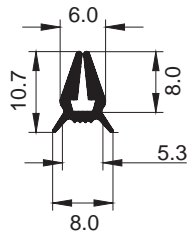

1:1

06 050 E7

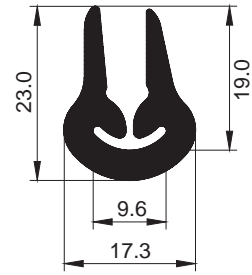

1:1

06 074 E7

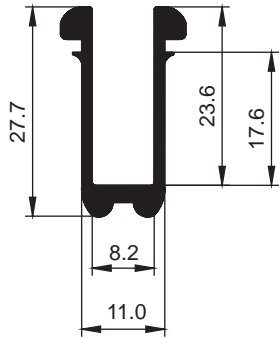

1:1

07 002 E7

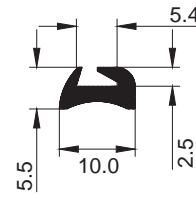

1:1

07 007 B7

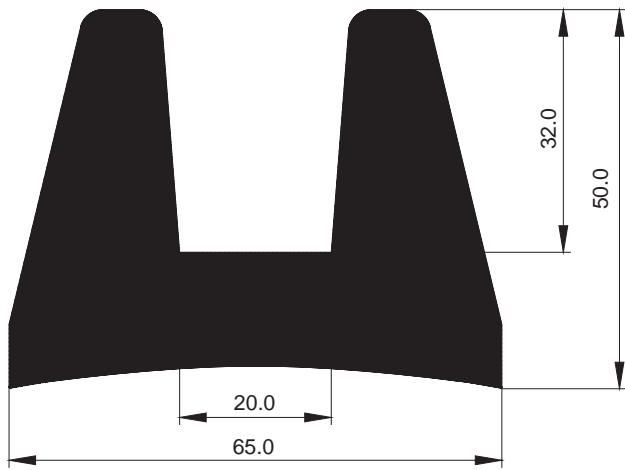

1:1

07 028 D6

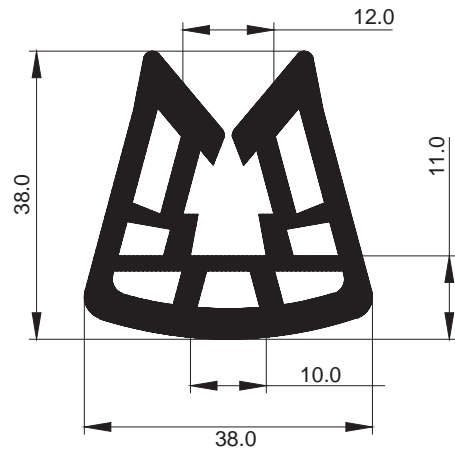

1:1

11 002 A8

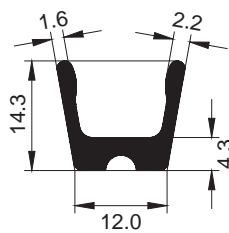

1:1

19 092 E6

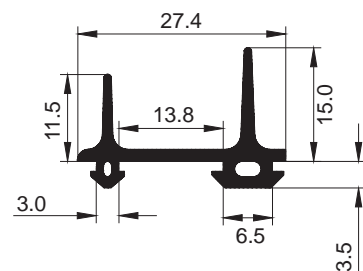

1:1

Round cords **Rundschnüre**

To order: from \varnothing 2 mm to 80 mm
Packing: as required

Nach Bestellung: von \varnothing 2 mm bis 80 mm
Verpackung: nach Absprache

Tubes without plies **Schläuche**

Marking: \varnothing inner dia. [mm] x wall thickness [mm]
To order: from 2 to 25 x 1,5 to 5 mm
Packing: as required

Kennzeichnung: \varnothing Innendurchmesser [mm] x Wanddicke [mm]
Nach Bestellung: von 2 bis 25 x von 1,5 bis 5 mm
Verpackung: nach Absprache

Square profiles **Rechteckprofile**

To order: from 4 x 4 to 40 x 40 mm
Packing: as required

Nach Bestellung: von 4 x 4 bis 40 x 40 mm
Verpackung: nach Absprache

02 046 E6

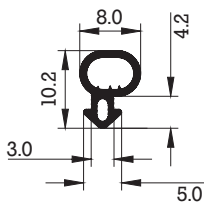

1:1

02 099 E6

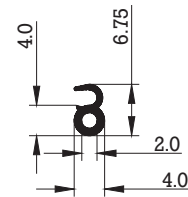

1:1

02 100 E6

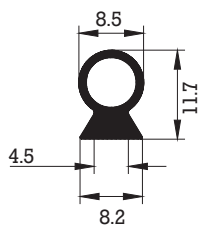

1:1

02 104 E6

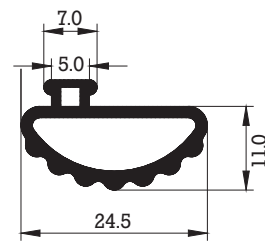

1:1

02 180 E7

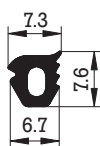

1:1

06 044 E5

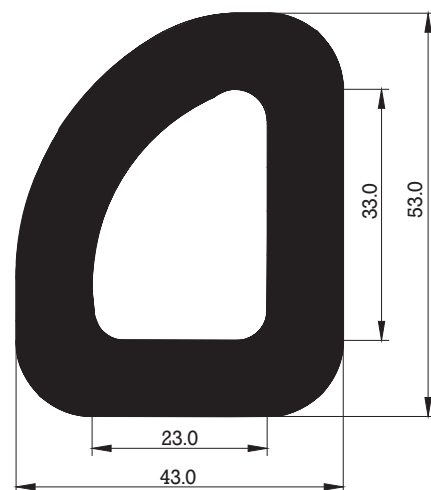

1:1

08 016 D6

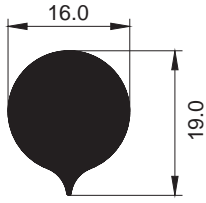

1:1

12 001 D4

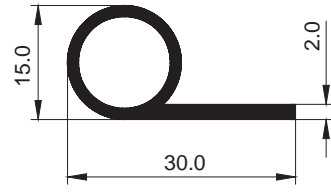

1:1

12 003 D6

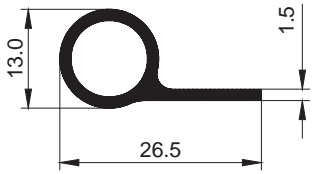

1:1

12 004 D6

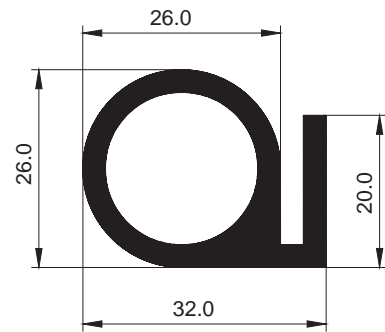

1:1

12 005 E6

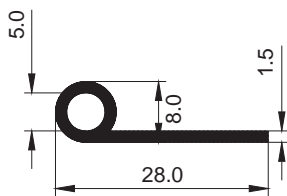

1:1

12 008 A6

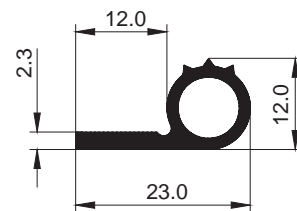

1:1

12 009 D6

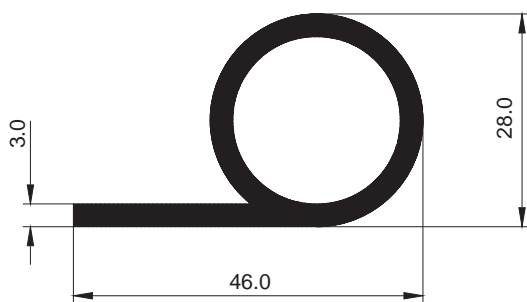

1:1

12 010 A4

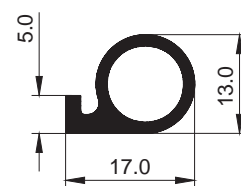

1:1

12 019 E6

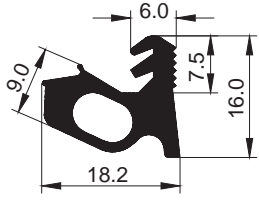

1:1

12 020 D5



1:1

12 022 E7

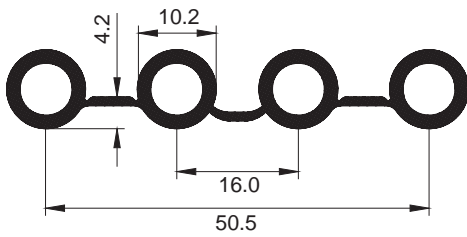

1:1

12 026 E7



1:1

12 027 E7

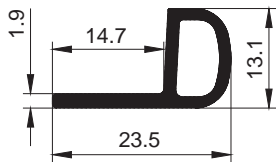

1:1

12 030 E8

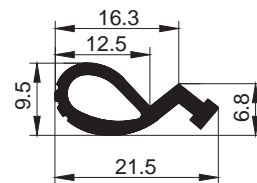

1:1

12 032 E6

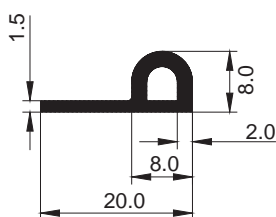

1:1

12 045 E6

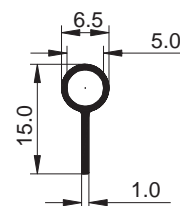

1:1

12 047 E8

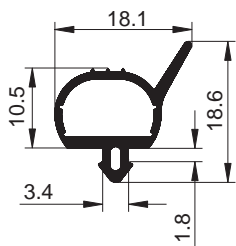

1:1

12 051 E7

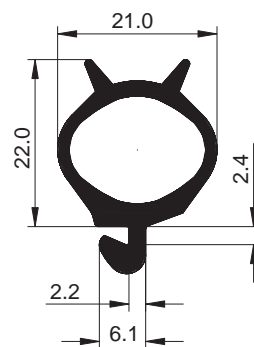

1:1

14 090 E8 kombiniran

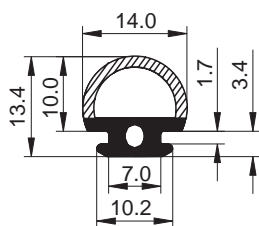

1:1

14 091 E6

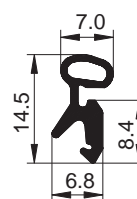

1:1

19 017 E5

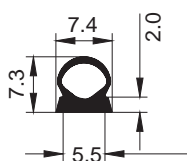

1:1

19 044 A6

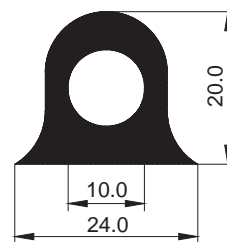

1:1

19 095 E6

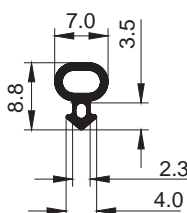

1:1

19 204 E6

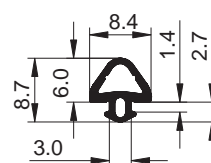

1:1

01 060 D6

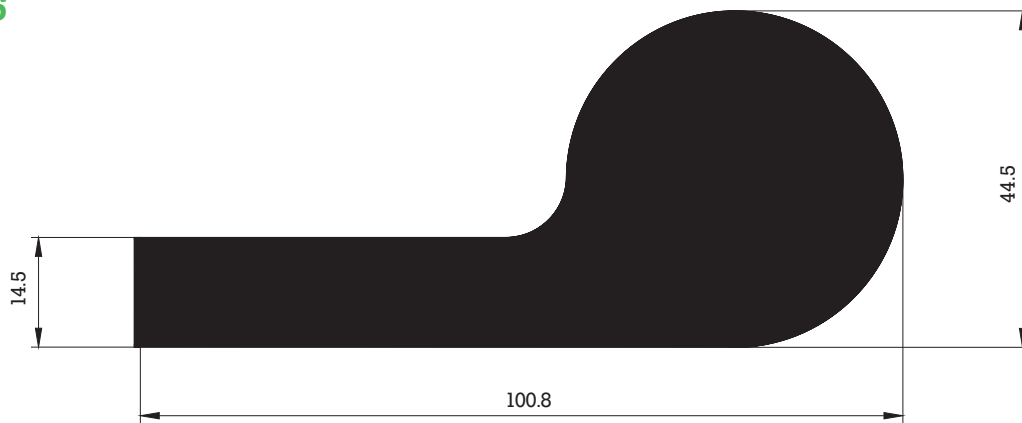

1:1

01 074 D5

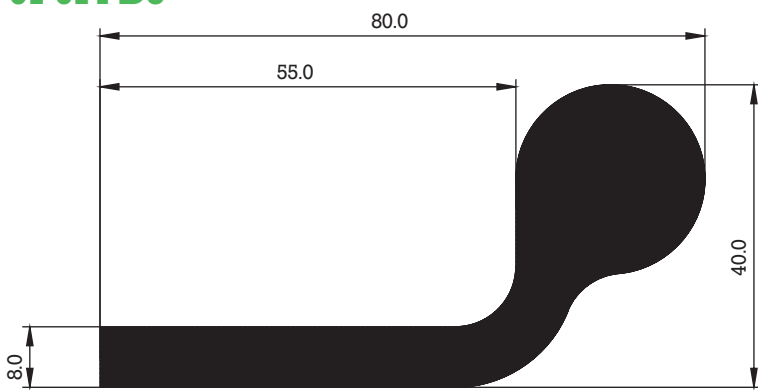

1:1

02 006 E6

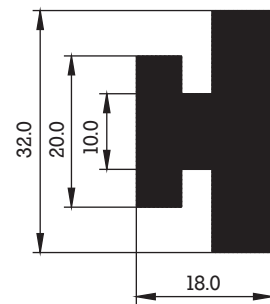

1:1

02 168 E6

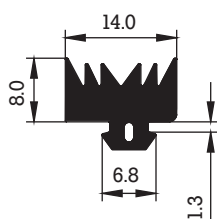

1:1

02 174 E6

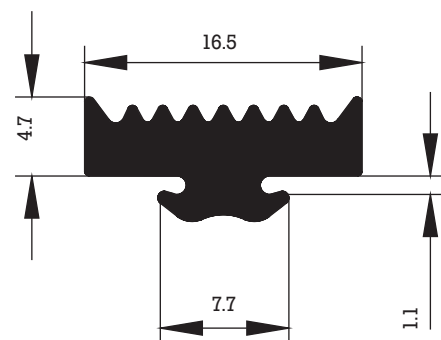

1:1

02 175 E6

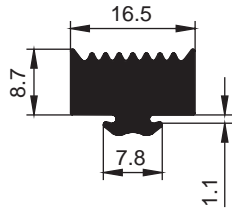

1:1

07 040 A6

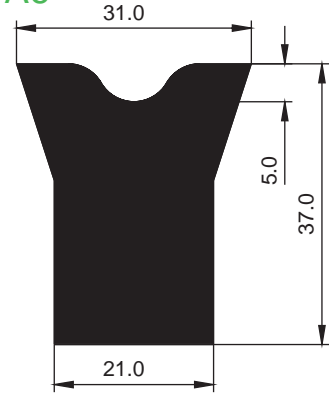

1:1

07 045 E6

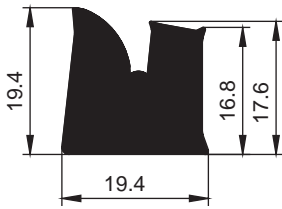

1:1

09 100 E6

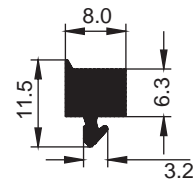

1:1

09 107 E7

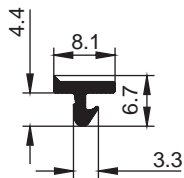

1:1

09 159 E7

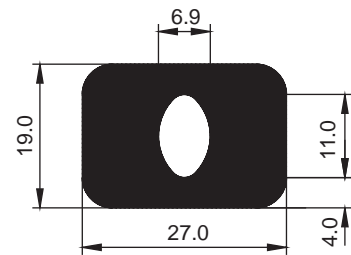

1:1

09 162 E7

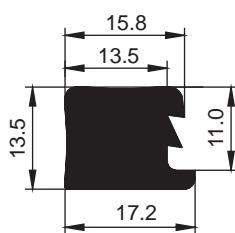

1:1

09 169 E6

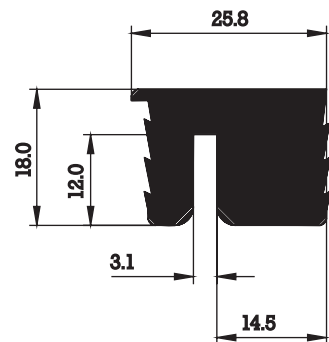

1:1

09 171 E7

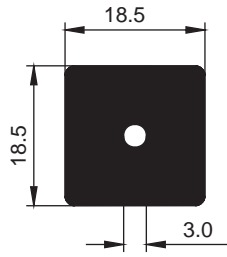

1:1

10 020 D6

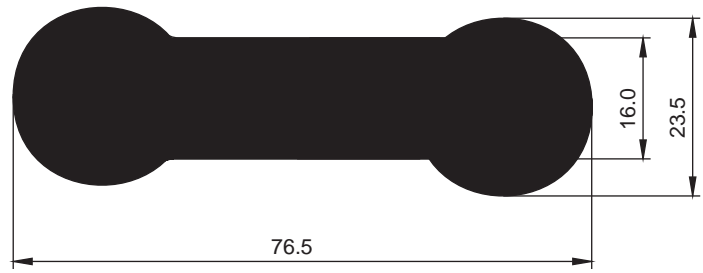

1:1

10 030 D6

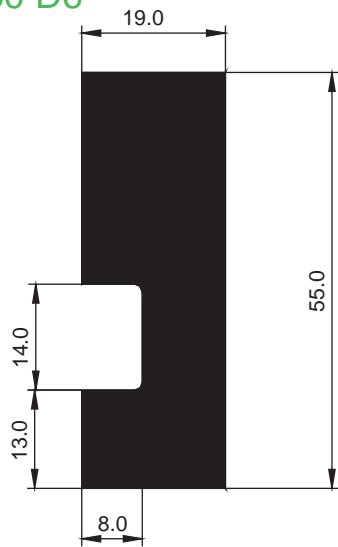

1:1

10 043 B8

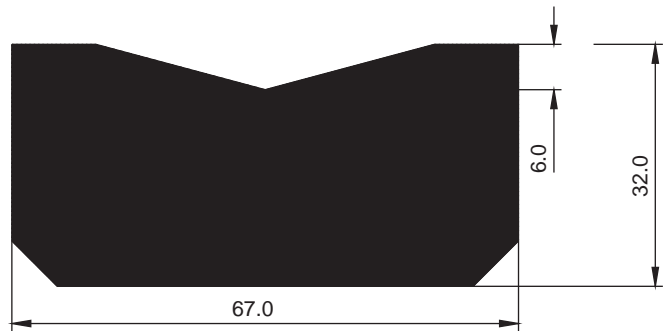

1:1

10 055 D8

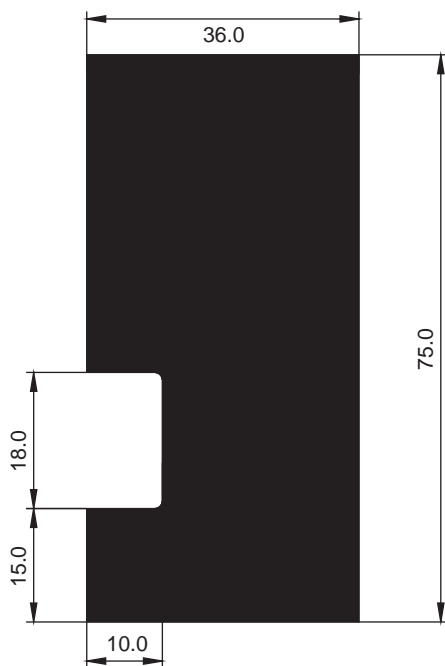

1:1

10 044 B8

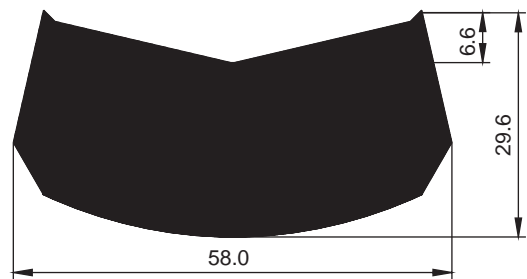

1:1

10 045 B8

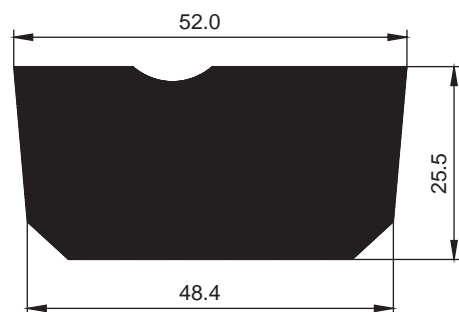

1:1

10 056 D6

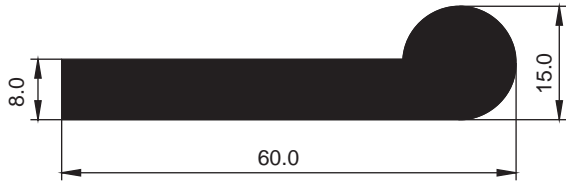

1:1

10 064 D6

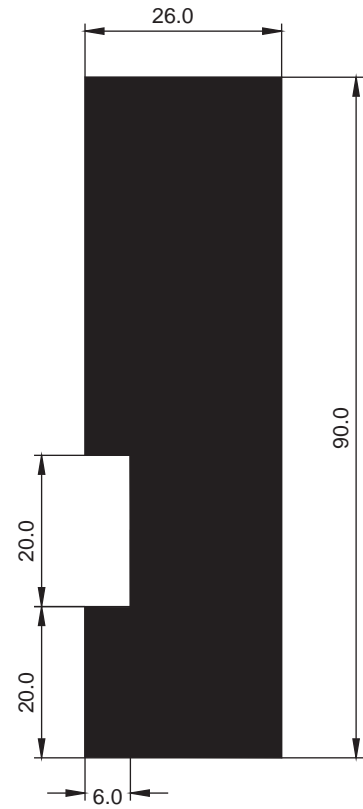

1:1

10 062 D8

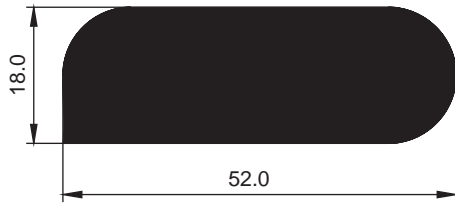

1:1

10 069 B8

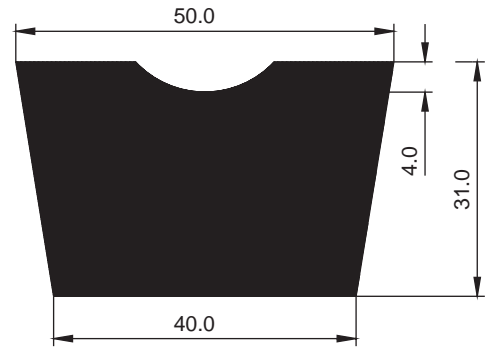

1:1

10 068 B8

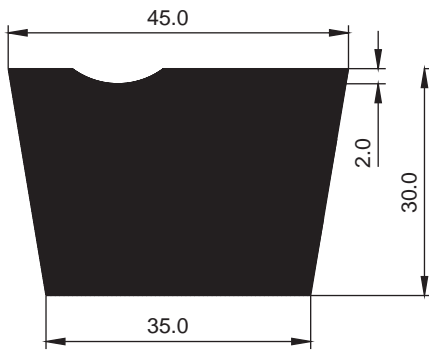

1:1

10 075 B8

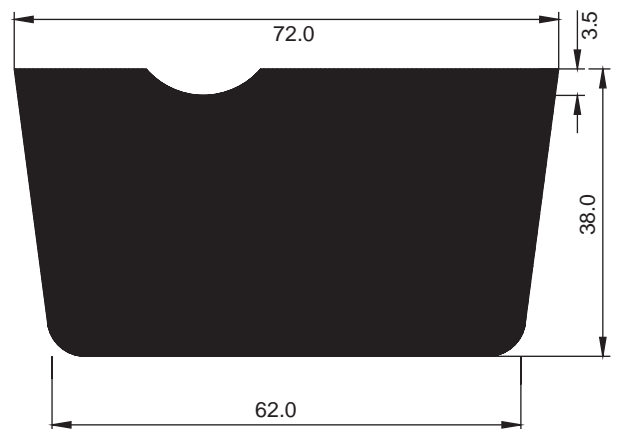

1:1

10 074 B8

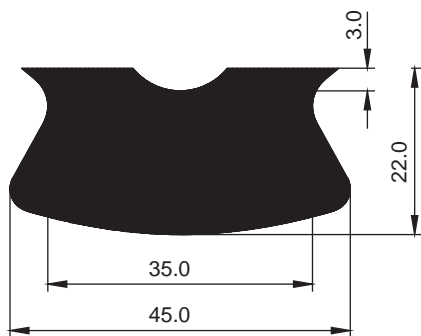

1:1

10 079 B8

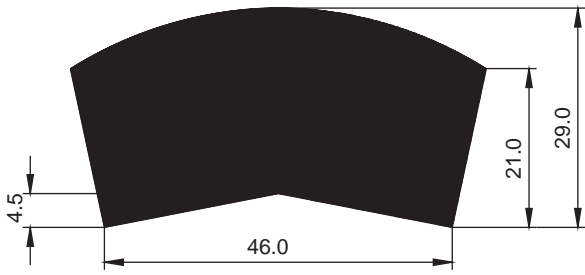

1:1

10 080 D8

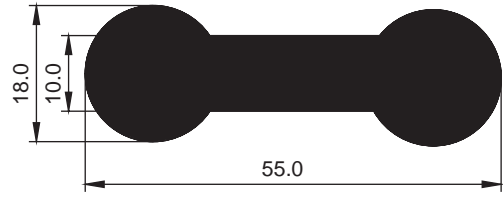

1:1

10 081 D8

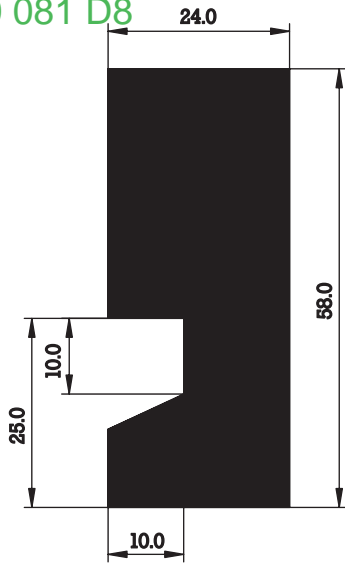

1:1

10 082 D6

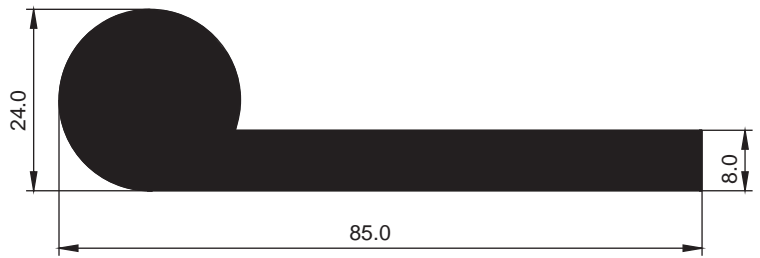

1:1

10 084 B8

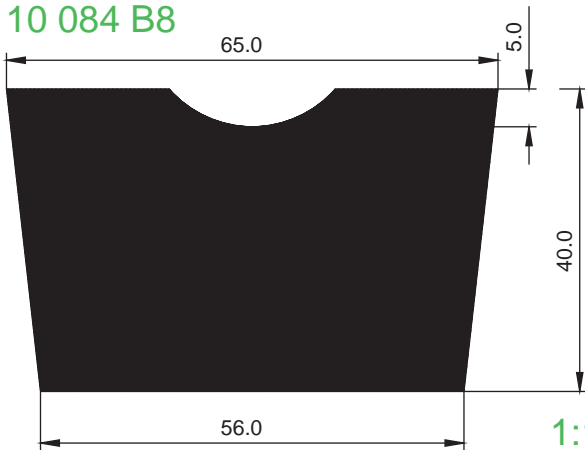

1:1

10 085 B8

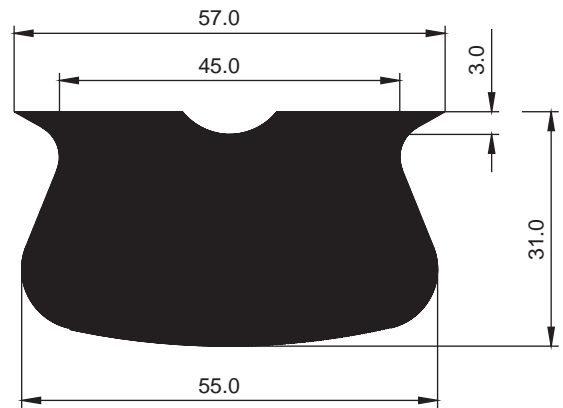

1:1

10 086 B8



1:1

10 092 D6

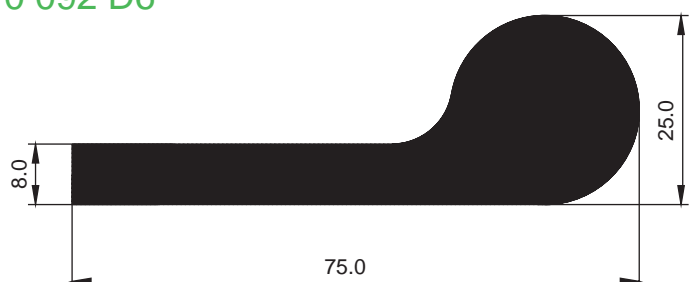

1:1

10 102 D8

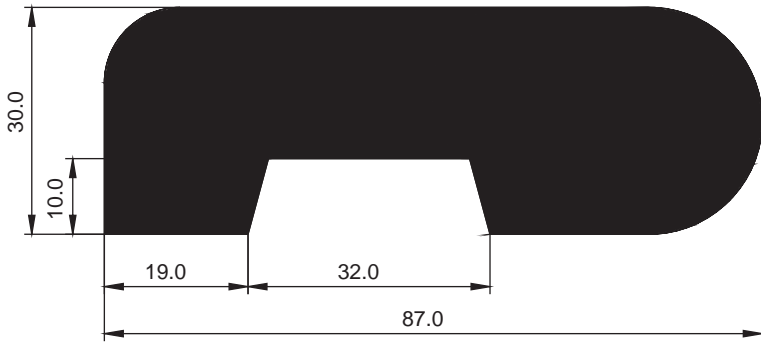

1:1

10 108 E7

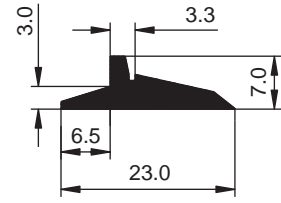

1:1

10 130 B8

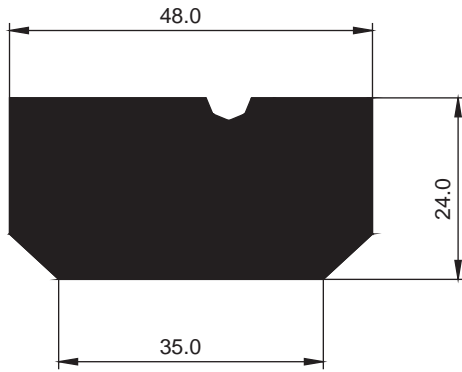

1:1

10 153 B8

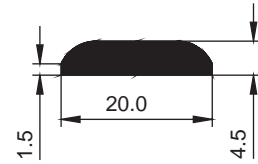

1:1

22 006 A7

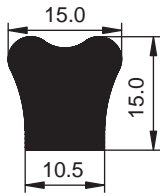

1:1

22 007 E7

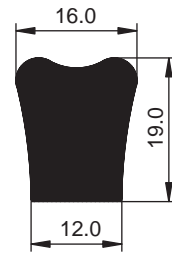

1:1

22 017 D4

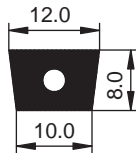

1:1

22 090 D6

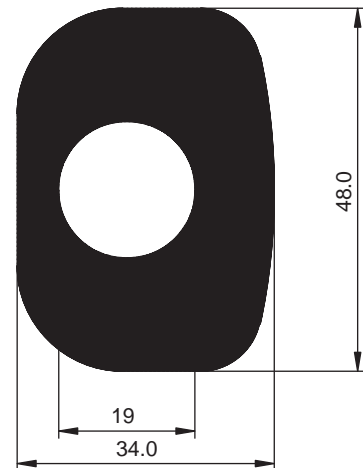

1:1

22 093 D6

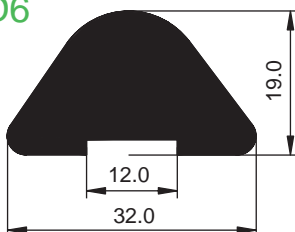

1:1

02 177 E6

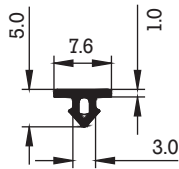

1:1

02 181 E6

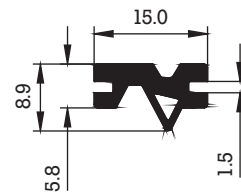

1:1

10 017 E7

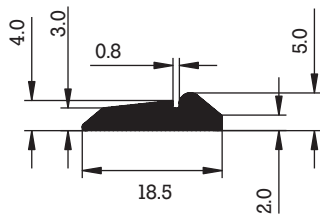

1:1

10 025 E7

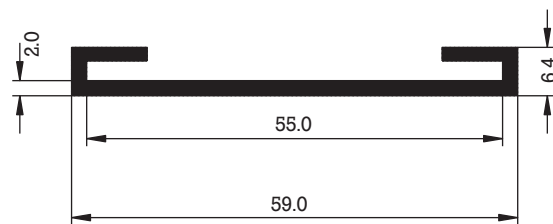

1:1

10 027 E7

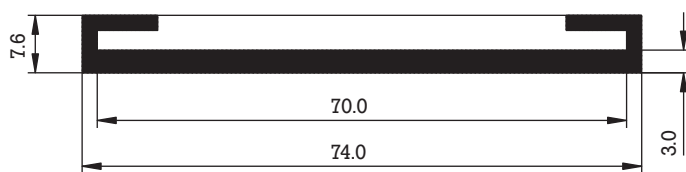

1:1

10 037 E6

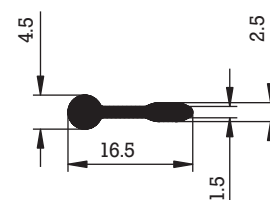

1:1

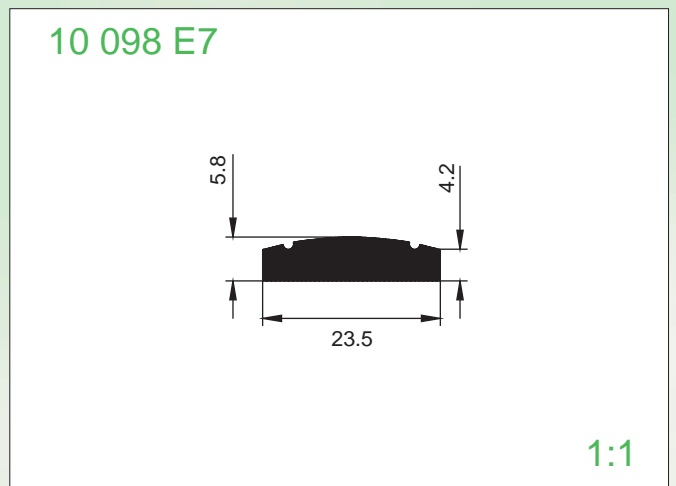
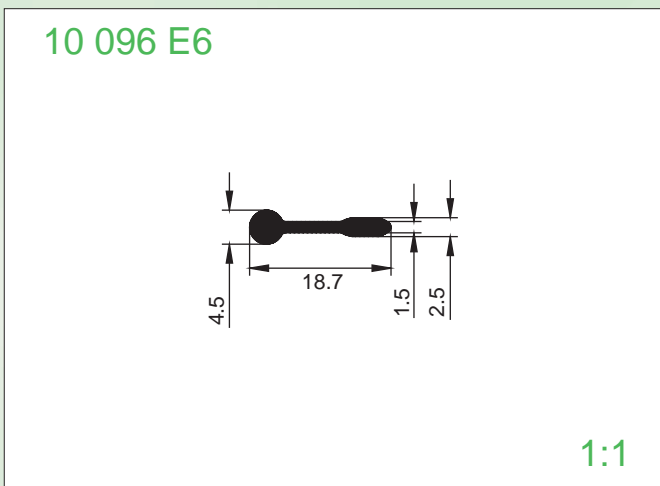
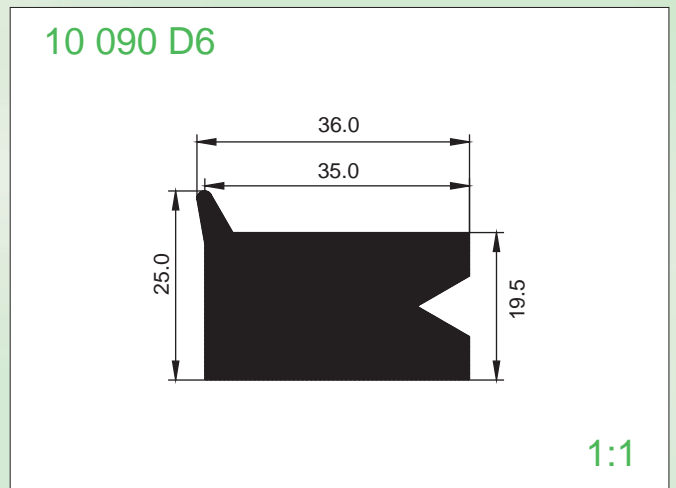
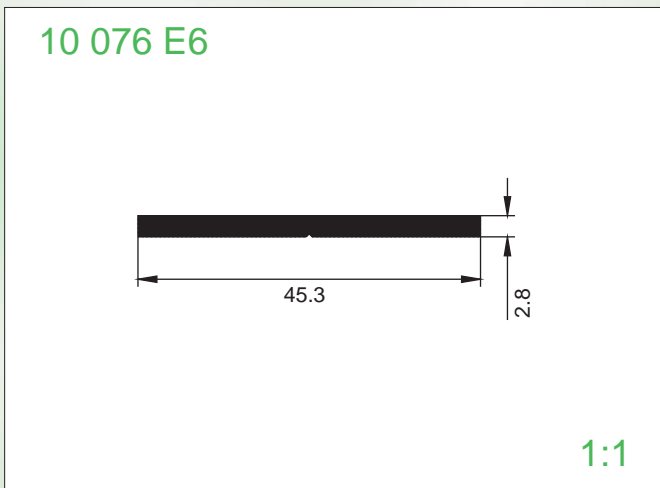
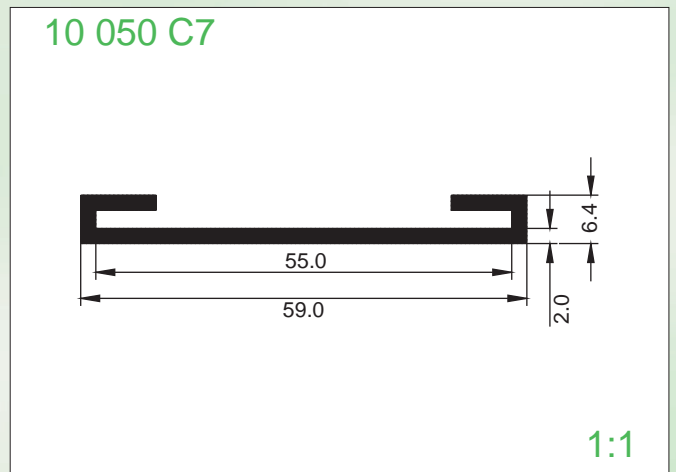
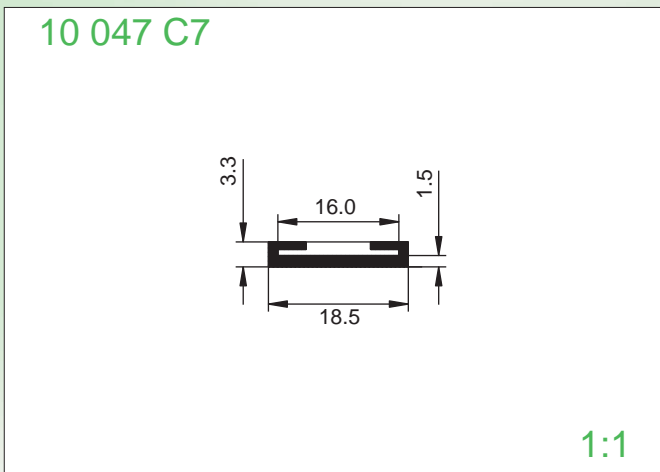
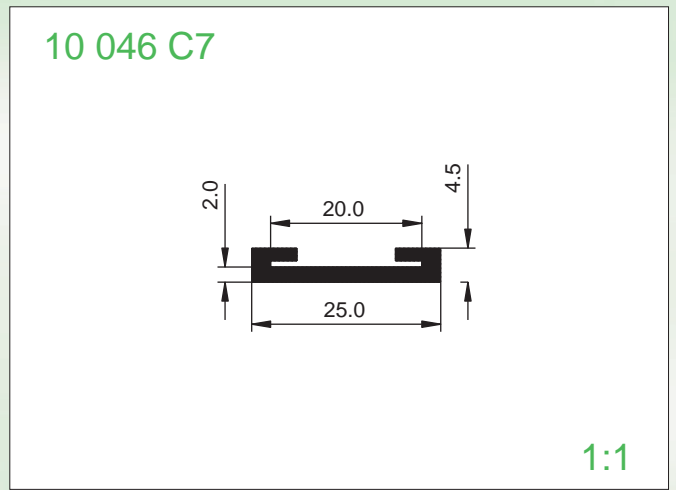
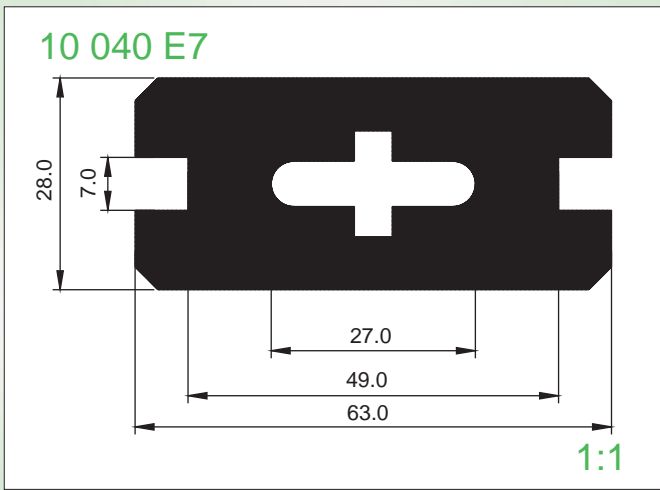

10 099 E5

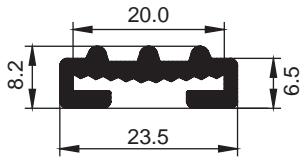

1:1

10 100 E7

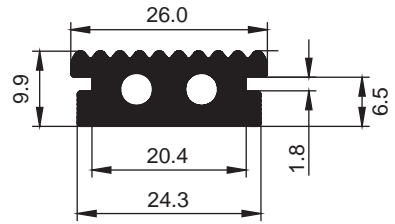

1:1

10 103 D8

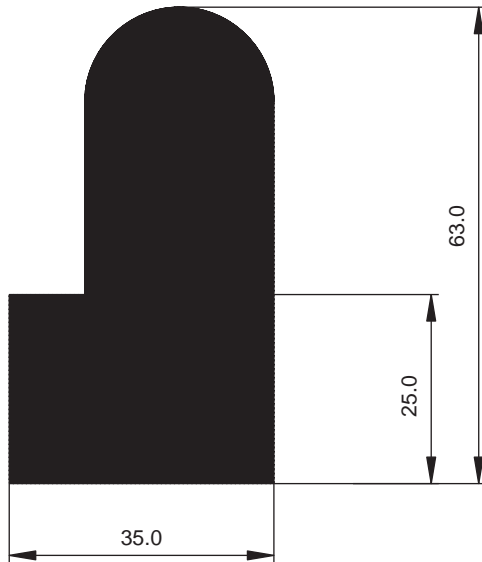

1:1

10 104 E6

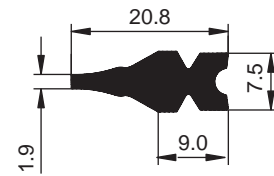

1:1

10 108 E7

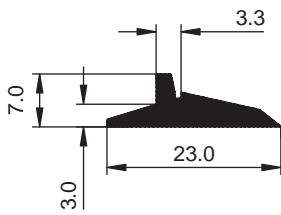

1:1

10 113 C7

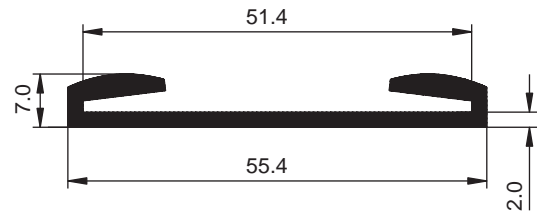

1:1

10 134 E5

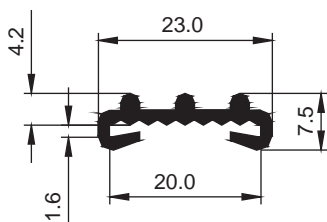

1:1

10 137 E5

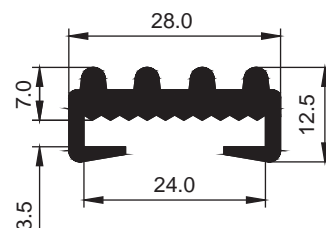

1:1

02 026 E5

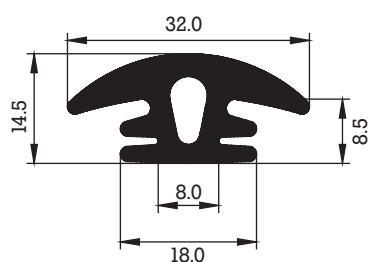

1:1

02 049 E7

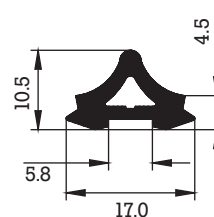

1:1

02 075 E6

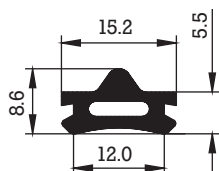

1:1

04 023 E6

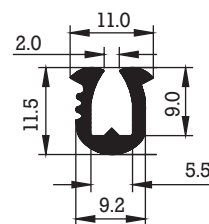

1:1

06 031 D4

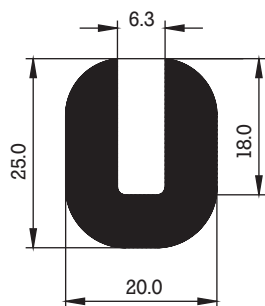

1:1

12 035 D6

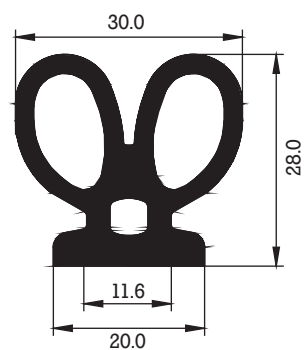

1:1

12 036 D6

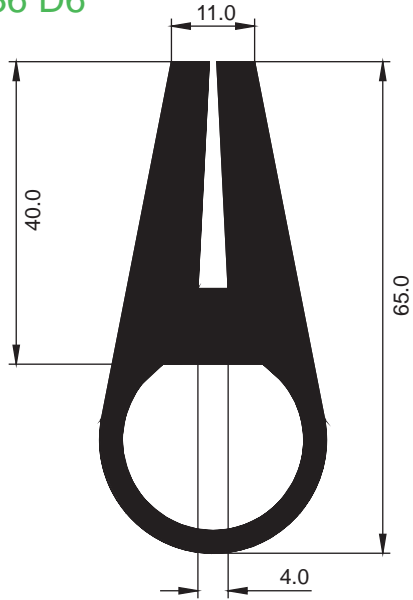

1:1

14 004 D6

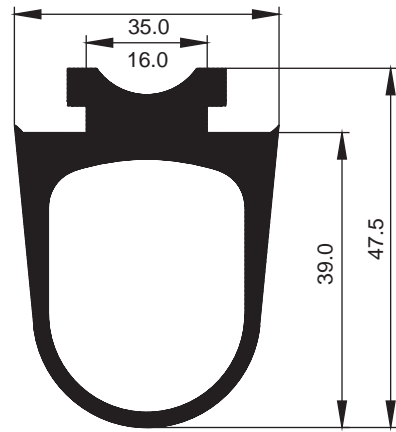

1:1

14 006 A6, E5

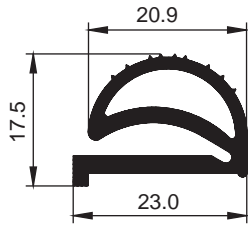

1:1

14 011 E7

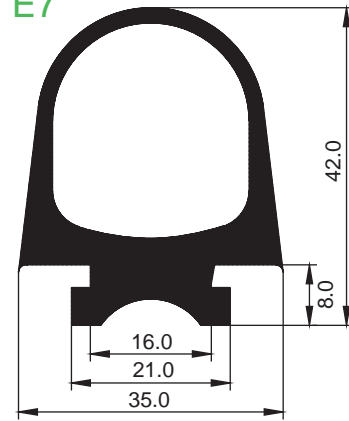

1:1

14 014 D4

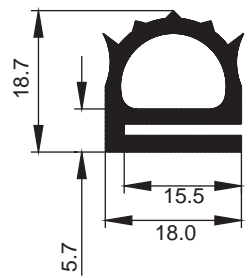

1:1

14 017 D5

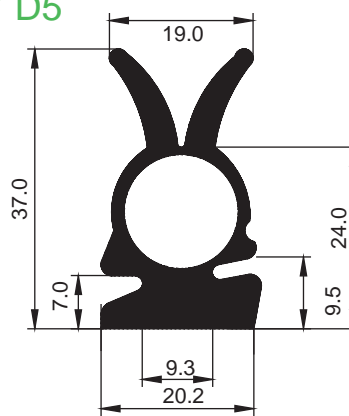

1:1

14 021 E7

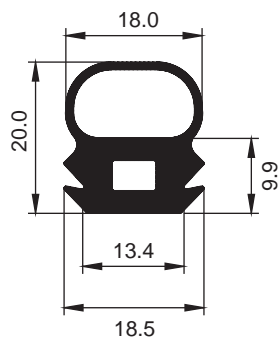

1:1

14 029 E7

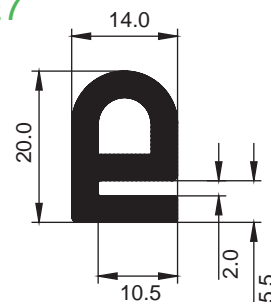

1:1

14 031 E7

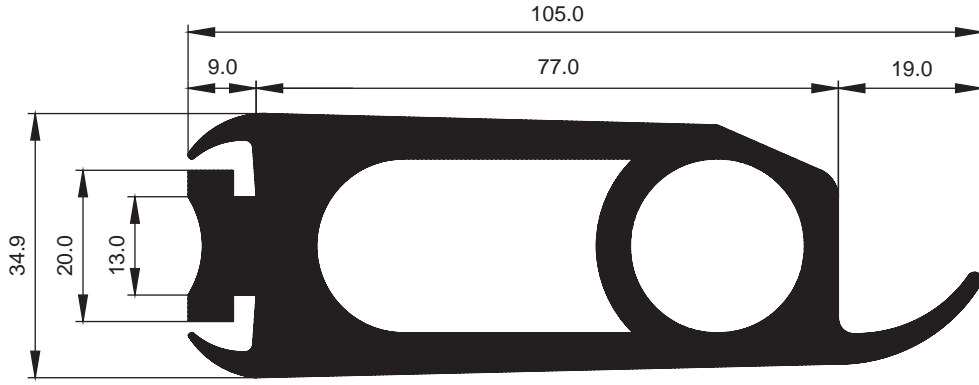

1:1

14 032 E6

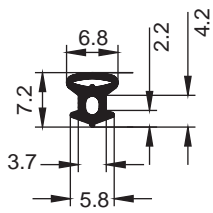

1:1

14 033 D4

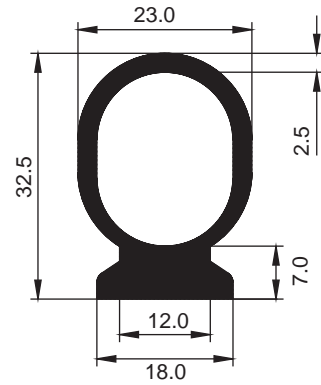

1:1

14 035 E7

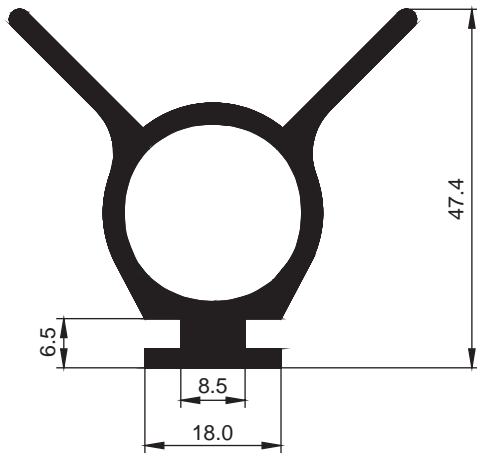

1:1

14 038 E5

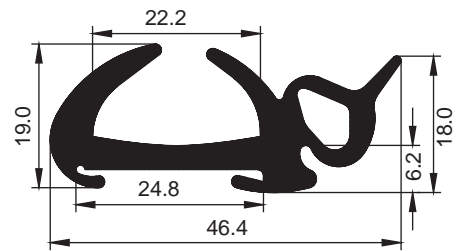

1:1

19 115 E6

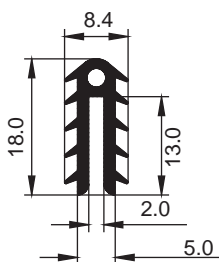

1:1

20 104 E7

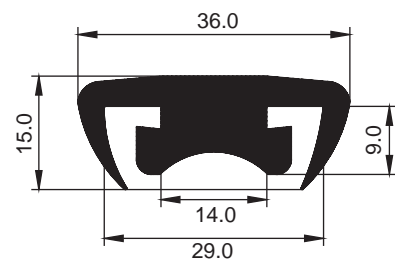

1:1

02 166 E6

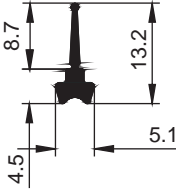

1:1

13 003 D6

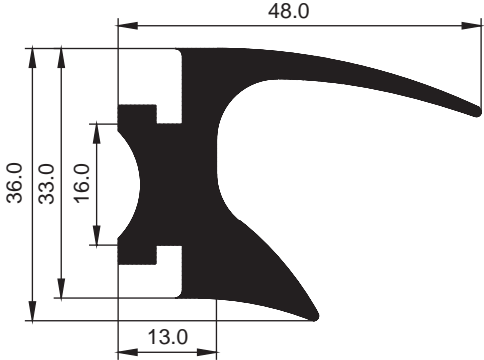

1:1

15 010 E7

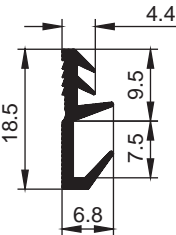

1:1

15 023 E5

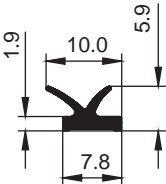

1:1

15 047 E6

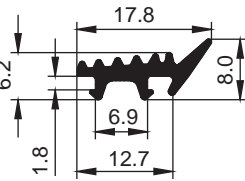

1:1

15 056 E6

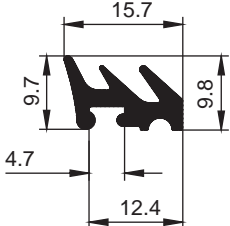

1:1

15 063 E6

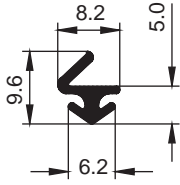

1:1

15 077 E6

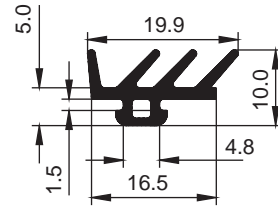

1:1

15 082 E6

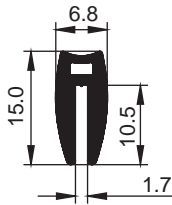

1:1

15 086 E6

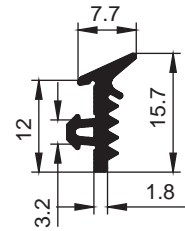

1:1

15 088 E6

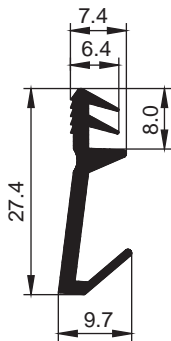

1:1

15 093 E6

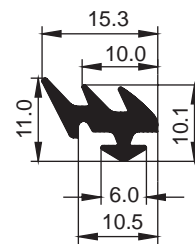

1:1

15 095 E6

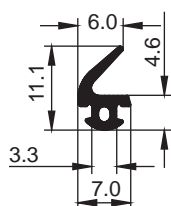

1:1

15 098 E6

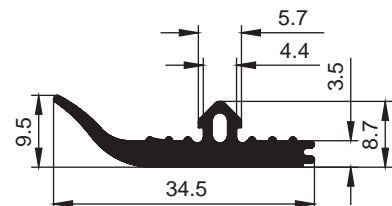

1:1

15 099 E6

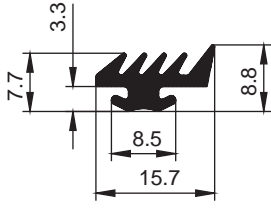

1:1

15 104 E7

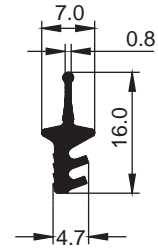

1:1

15 127 E6

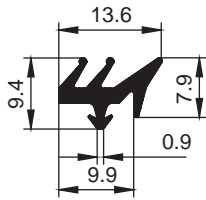

1:1

15 135 E6

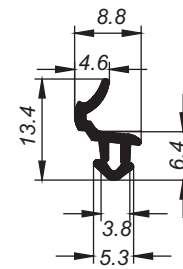

1:1

15 137 E6

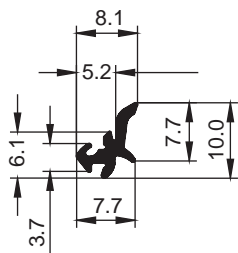

1:1

15 144 E6

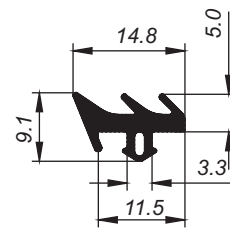

1:1

15 150 E7

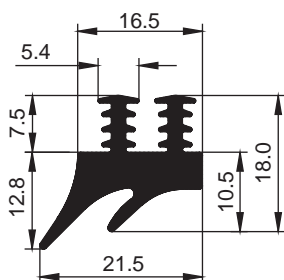

1:1

15 152 E6

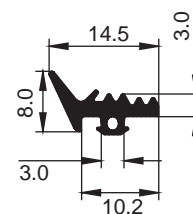

1:1

15 161 E6

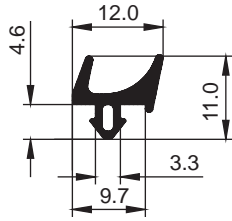

1:1

15 163 E6

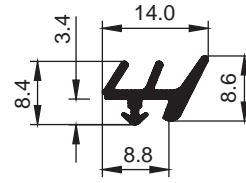

1:1

15 164 E6

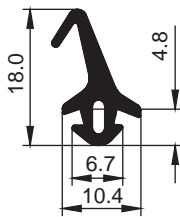

1:1

15 168 E6

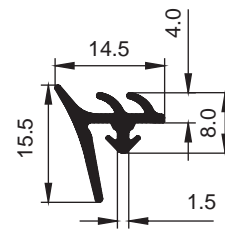

1:1

15 278 E6

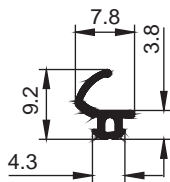

1:1

15 292 E6

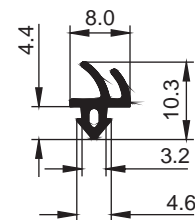

1:1

15 320 E6

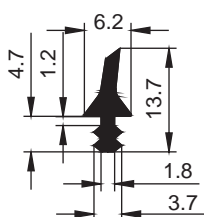

1:1

15 322 E6

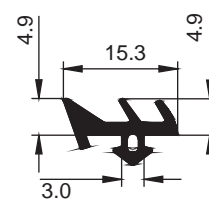

1:1

19 056 E6

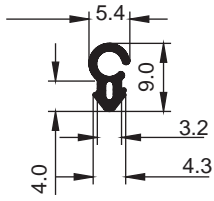

1:1

19 080 E7

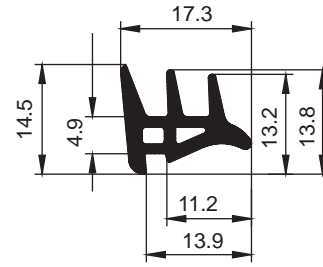

1:1

19 084 E6

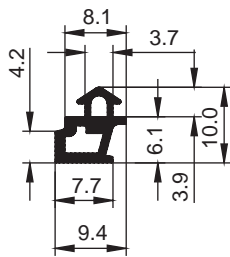

1:1

19 105 E5

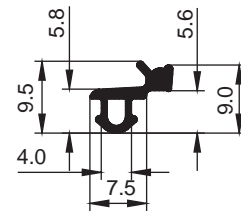

1:1

19 116 E6, E7

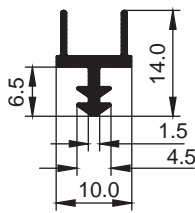

1:1

19 131 E6

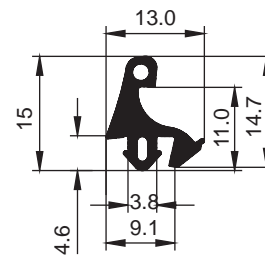

1:1

20 070 E7

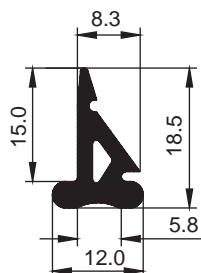

1:1

20 102 E6

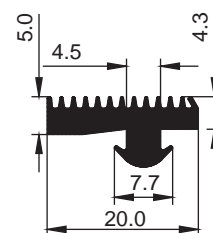

1:1

20 121 E6

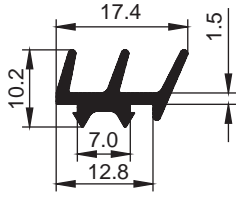

1:1

20 135 E7

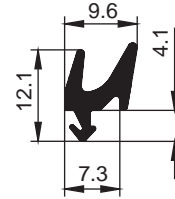

1:1

20 136 E6

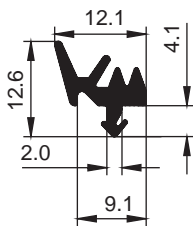

1:1

20 143 E6

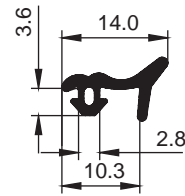

1:1

20 151 E8

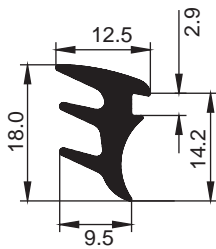

1:1

20 157 E6

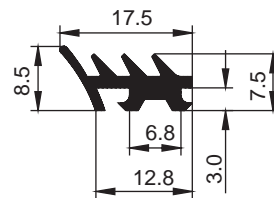

1:1

20 158 E6

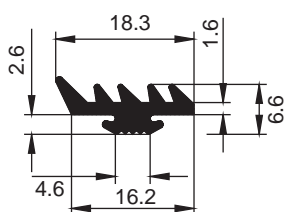

1:1

20 161 E7

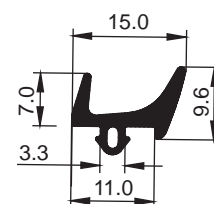

1:1

20 163 E6

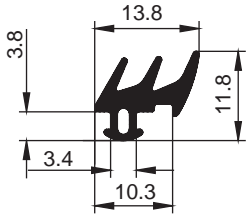

1:1

20 164 E8

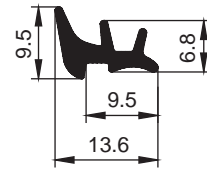

1:1

20 165 E8

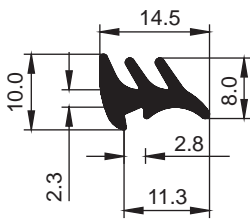

1:1

20 175 E7

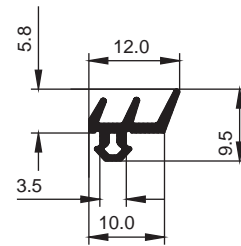

1:1

20 180 E6

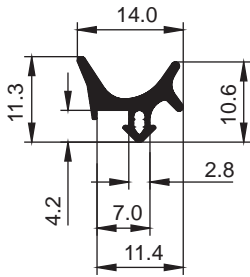

1:1

20 182 E7

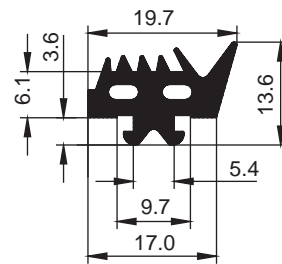

1:1

20 184 E6

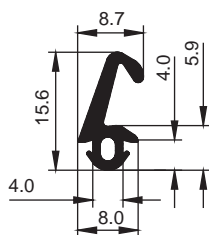

1:1

20 257 E6

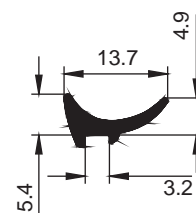

1:1

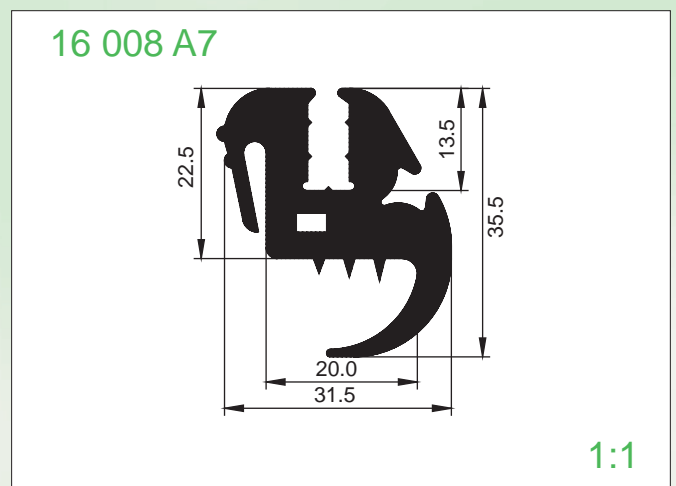
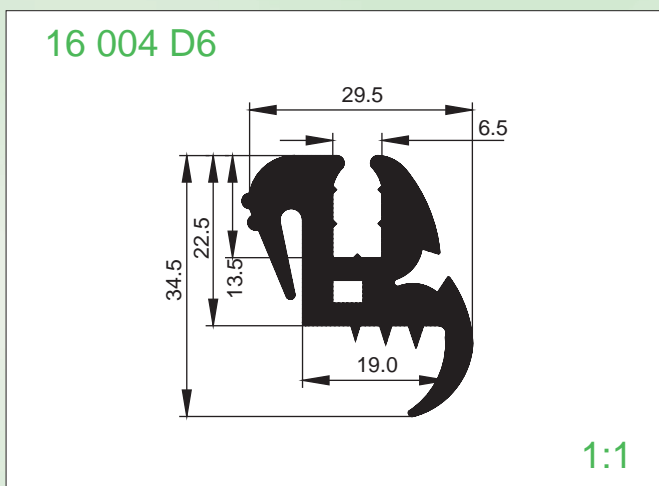
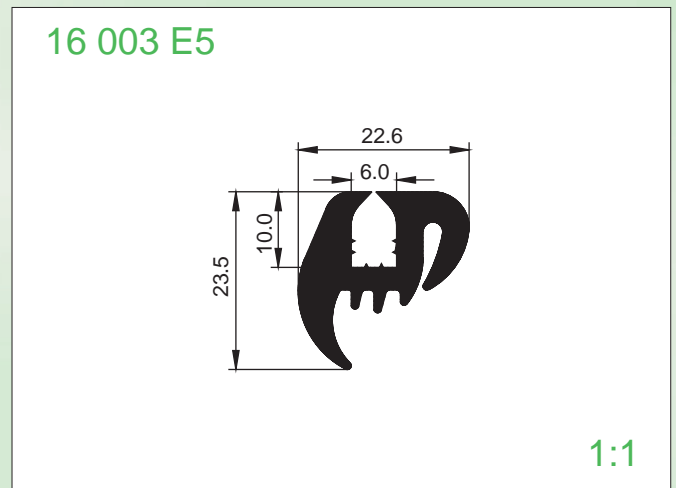
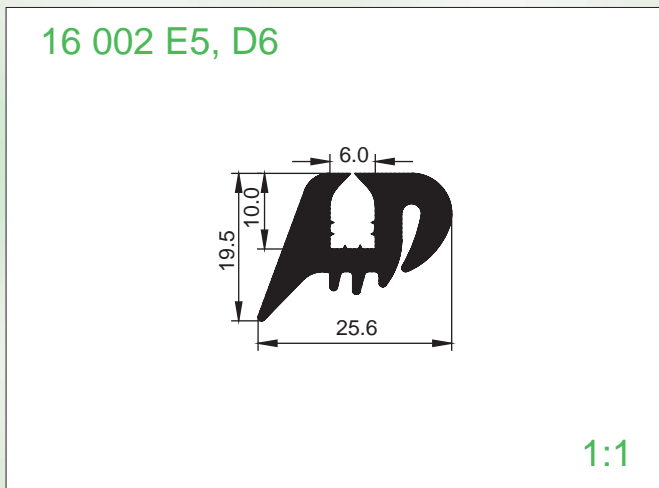
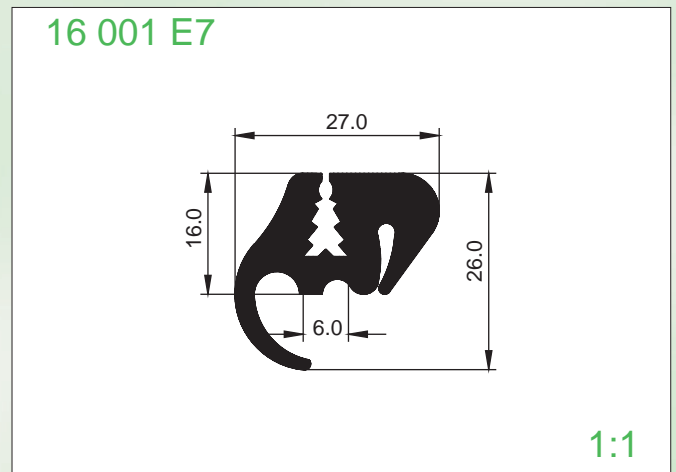
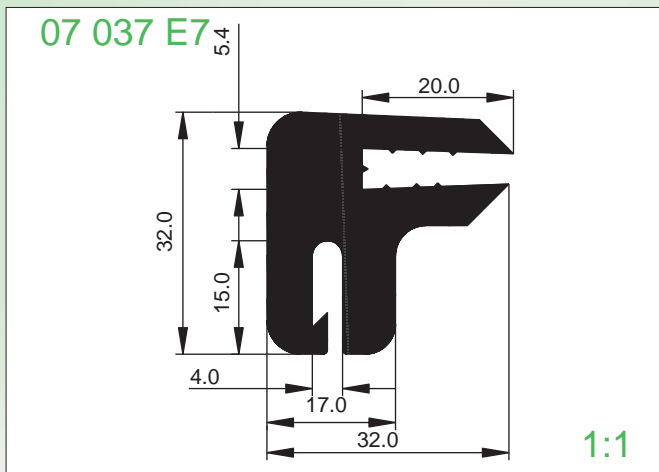

16 022 E5

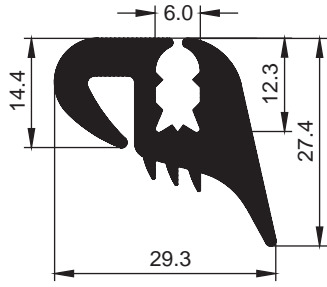

1:1

16 023 D6

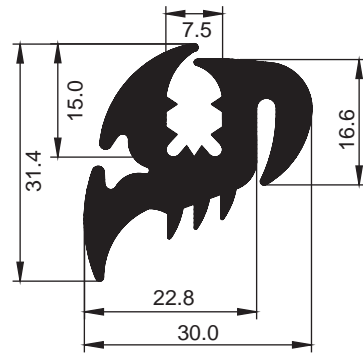

1:1

16 025 E6

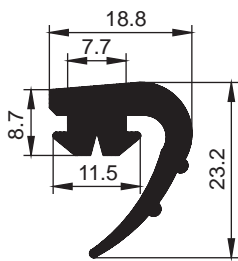

1:1

16 028 E7

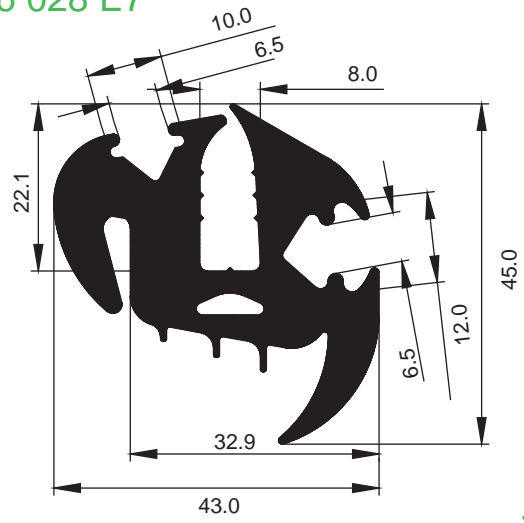

1:1

16 029 D6

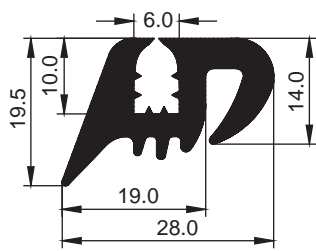

1:1

17 002 E7, D8

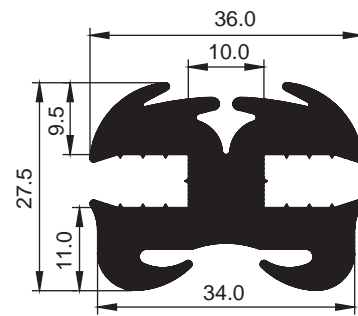

1:1

17 009 E5

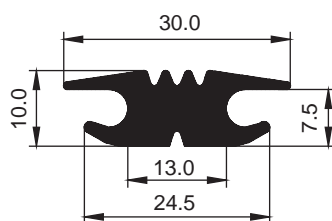

1:1

18 001 E7

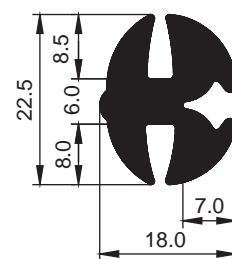

1:1

18 002 E7, D4

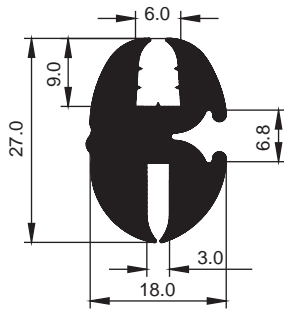

1:1

18 003 E7

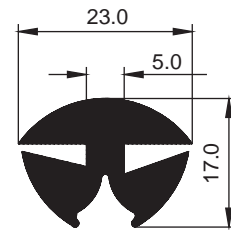

1:1

18 009 D6

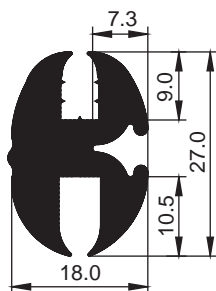

1:1

18 012 D6

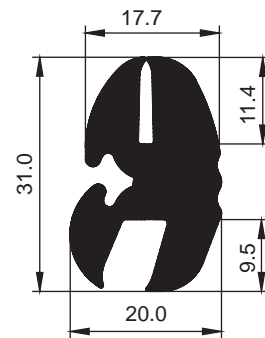

1:1

18 026 E7

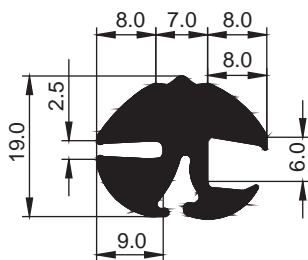

1:1

18 030 E9 komb

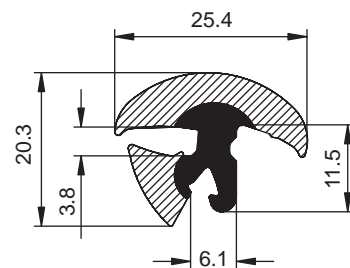

1:1

18 031 E9 komb

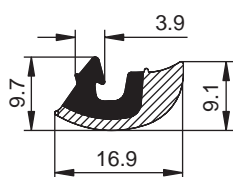

1:1

20 008 E7

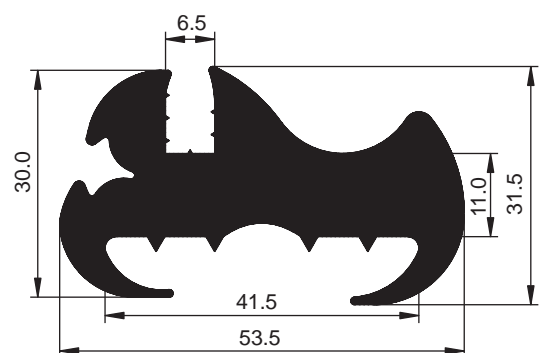

1:1

20 013 E7

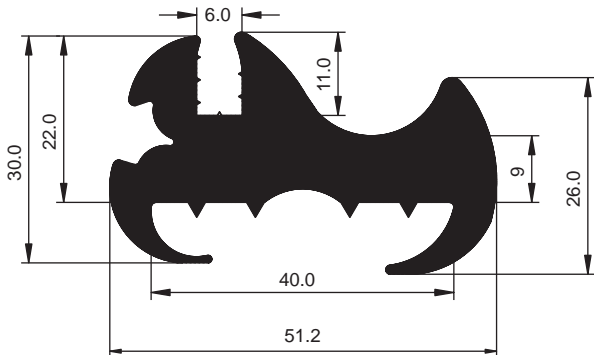

1:1

20 022 E7

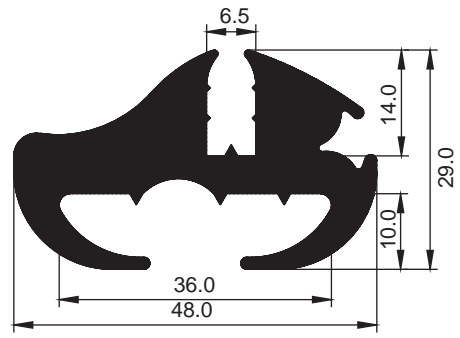

1:1

20 023 E7

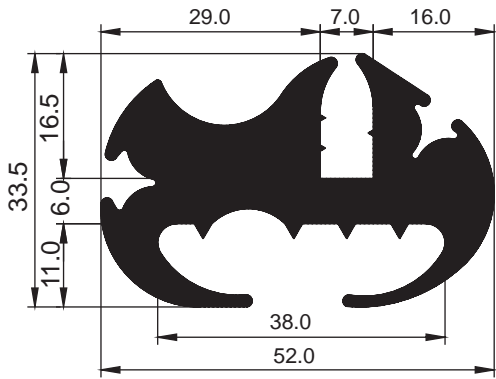

1:1

20 029 E7

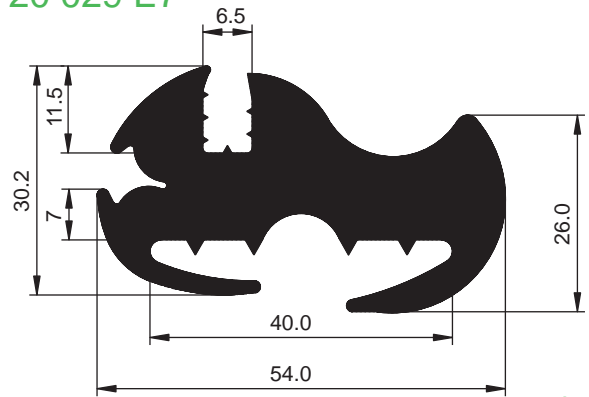

1:1

20 089 E6

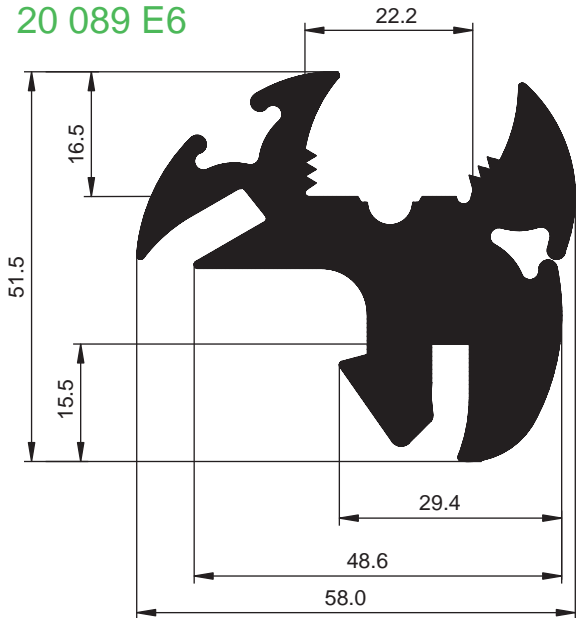

1:1

20 043 E7

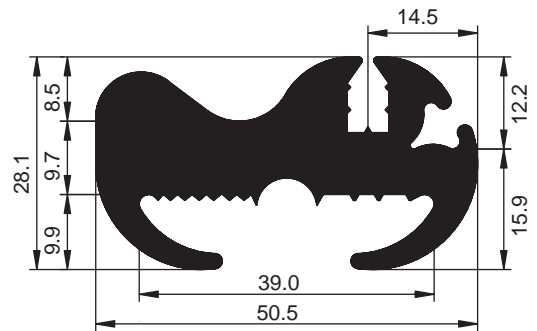

1:1

20 103 E7

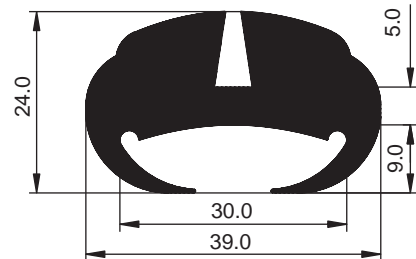

1:1

22 032 E7

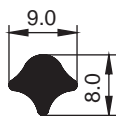

1:1

Window Profiles - Medium

Dichtungsprofile für Fenster - Mitteldichtung

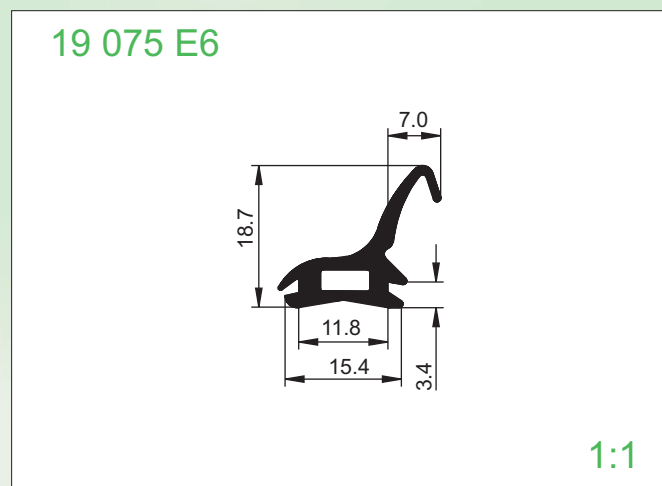
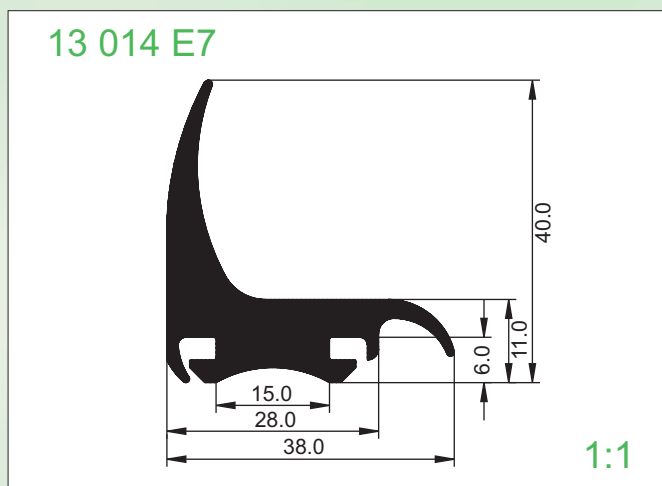
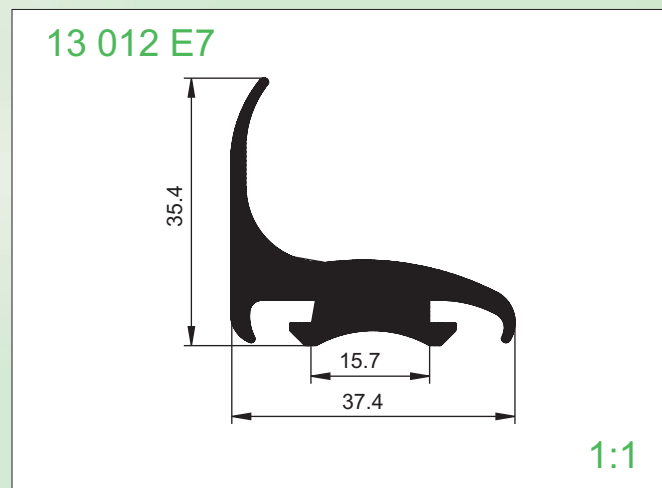
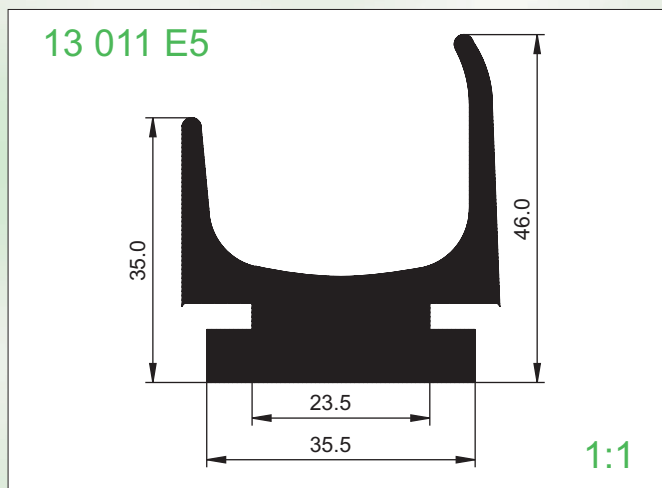
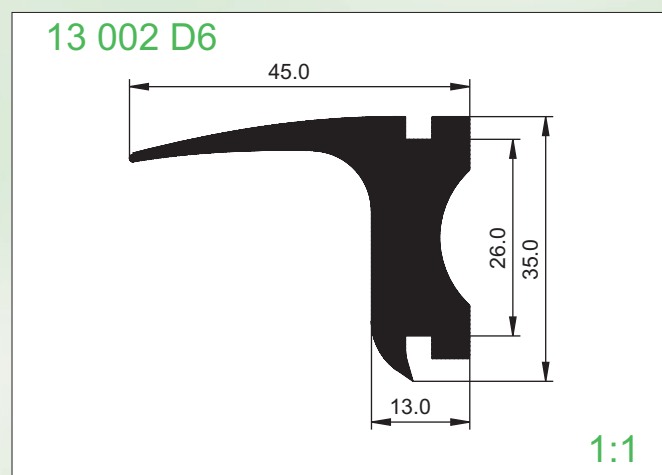
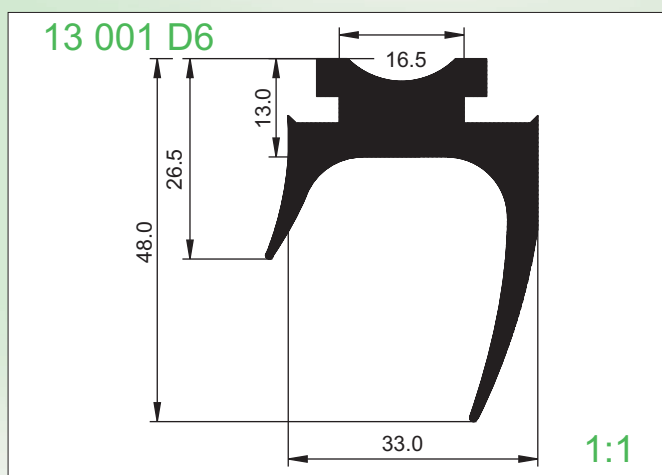

19 091 E6

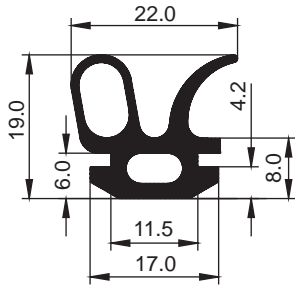

1:1

19 108 E6

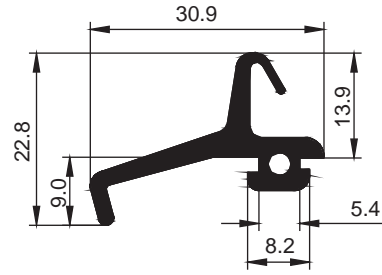

1:1

19 112 E6

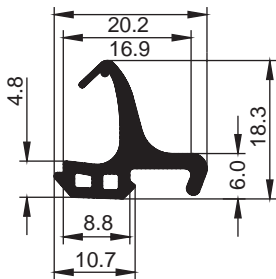

1:1

19 135 E7

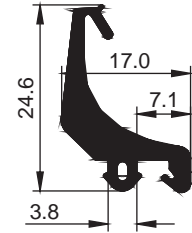

1:1

19 159 E6

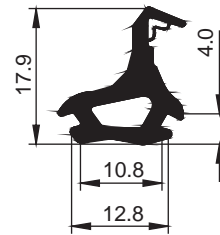

1:1

19 158 E6

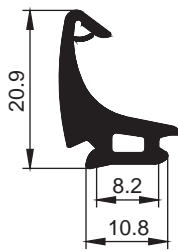

1:1

19 201 E6

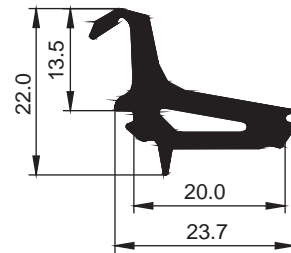

1:1

19 174 E7

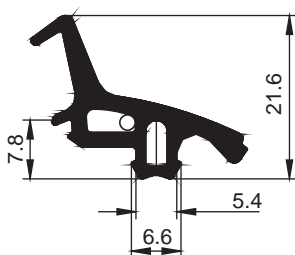

1:1

19 206 E6

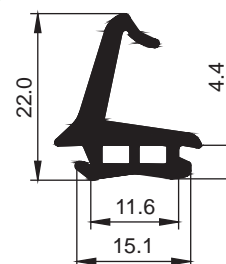

1:1

05 031 D5

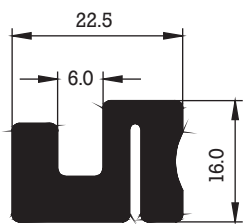

1:1

22 008 E7

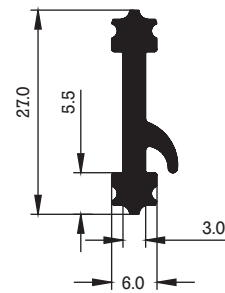

1:1

22 190 E7

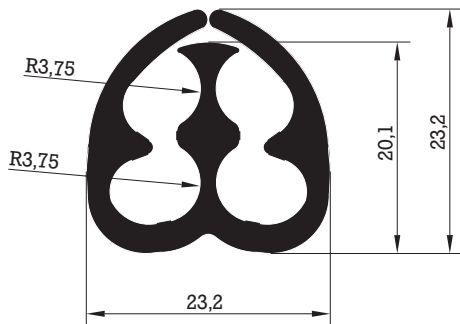

1:1

22 055 E7

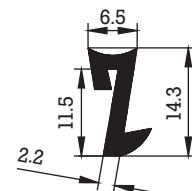

1:1

05 034 E7



1:1

22 023 A7

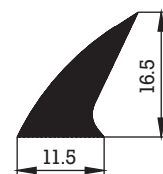

1:1

22 060 C7

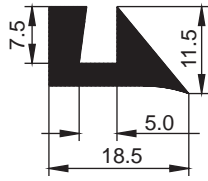

1:1

22 073 E7

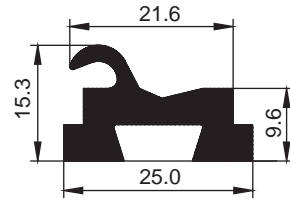

1:1

22 092 A5

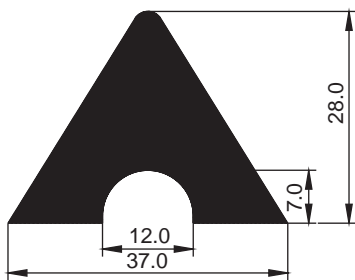

1:1

22 094 D6

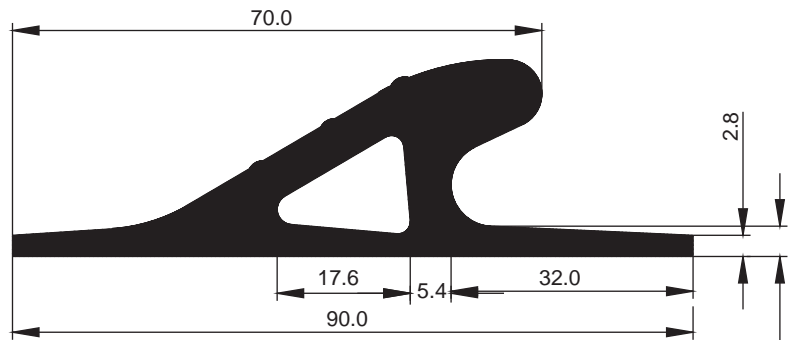

1:1

22 095 E6

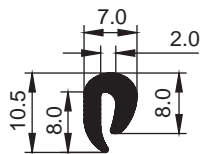

1:1

22 098 D4

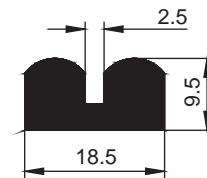

1:1

22 099 E5

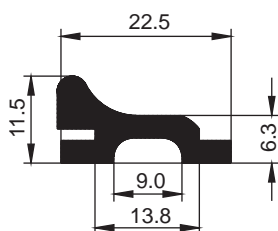

1:1

22 100 D6

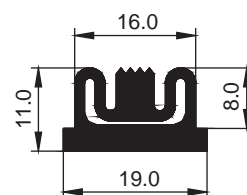

1:1

22 113 E8

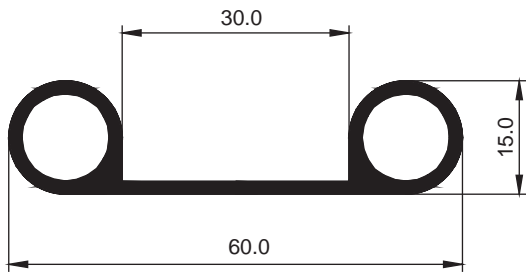

1:1

22 134 E8

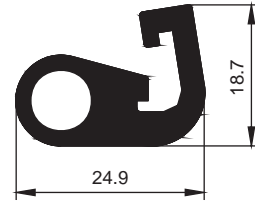

1:1

22 152 C7

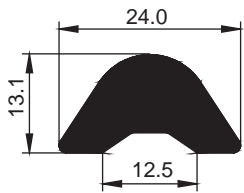

1:1

22 154 E8

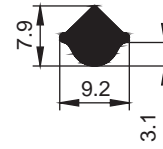

1:1

22 155 E8

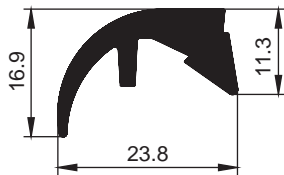

1:1

22 156 C7

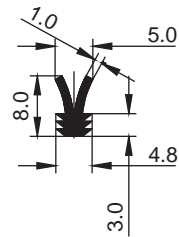

1:1

22 173 E7

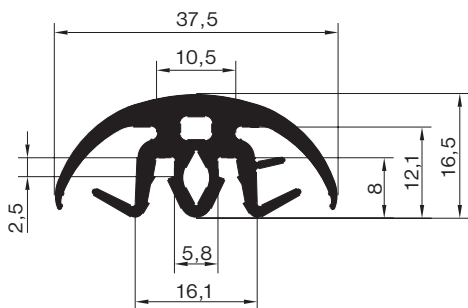

1:1

22 163 E5

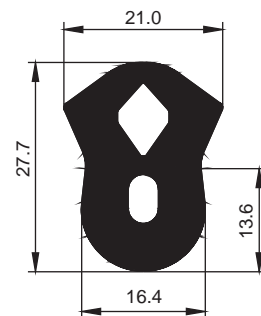

1:1

Companies in Slovenia and abroad Gesellschaften in Slowenien und im Ausland

Slovenia / Slowenien:

SAVATECH d.o.o.

Škofjeloška c. 6, 4502 Kranj
Tel.: 00386 / 4 / 2066 471, Fax: 00386 / 4 / 2065 475
E-mail: meta.sajovic@sava.si

Niederlassungen in Europa:

Germany / Deutschland:

SAVA TRADE, Vertriebsgesellschaft GmbH

Kobellstraße 4, 80336 München
Tel.: 0049 / 89 / 5 44 1430, Fax: 0049 / 89 / 5 32 89 51
E-mail: zlatko.smrdele@sava-trade.de

SAVA TRADE

Vertriebsgesellschaft GmbH München, Vertriebsbüro Nürnberg

Pilotystraße 5, 90408 Nürnberg
Tel.: 0049 / 911 / 9 3 59 48-0, Fax: 0049 / 911 / 93 59 48-48
E-mail: maik.sohr@sava-trade.de

Great Britain / Großbritannien:

SAVA TECH TRADE LTD.

Airport House, Purley Way, Croydon, Surrey CRO 0XZ
Tel.: 0044 / 20 / 82 88 35 08, Fax: 0044 / 20 / 86 88 00 55
E-mail: bostjan.podjed@savatech.co.uk

Poland / Polen:

SAVA TRADE sp.z.o.o.

Ul. Przyparkowa 19, 05-850 Ozarów Mazowiecki, Jawczyce
Tel.: 0048 / 22 / 721 17 51, Fax: 0048 / 22 / 721 13 62
E-mail: ryszard.zawadzki@savatrade.com.pl

Czech Republic / Tschechien:

SAVA TRADE s.r.o.

Sokolska 66, 12000 Praha 2
Tel.: 0042 / 022 / 494 19 66, Fax: 0042 / 022 / 494 25 59
E-mail: petr.brezina@savatrade.cz

Vertretungen:

Russia / Russland:

SAVATECH d.o.o.

Representative Office in Moscow
Ul. DM Uljanowa 16/2, apt. 127, 117292 Moscow
Tel.: 007 / 095 / 775 38 46, Fax: 007 / 095 / 775 38 47
E-mail: branimir.andjelic@savatech.ru

Italy / Italien:

SAVATECH d.d.o.

Ufficio di rappresentanza per l'Italia
Col 54, 34016 Trieste
Tel.: 0039 / 040 / 2 028082, Fax: 0039 / 040 / 2 028053
E-mail: ivan.zobec@sava.si

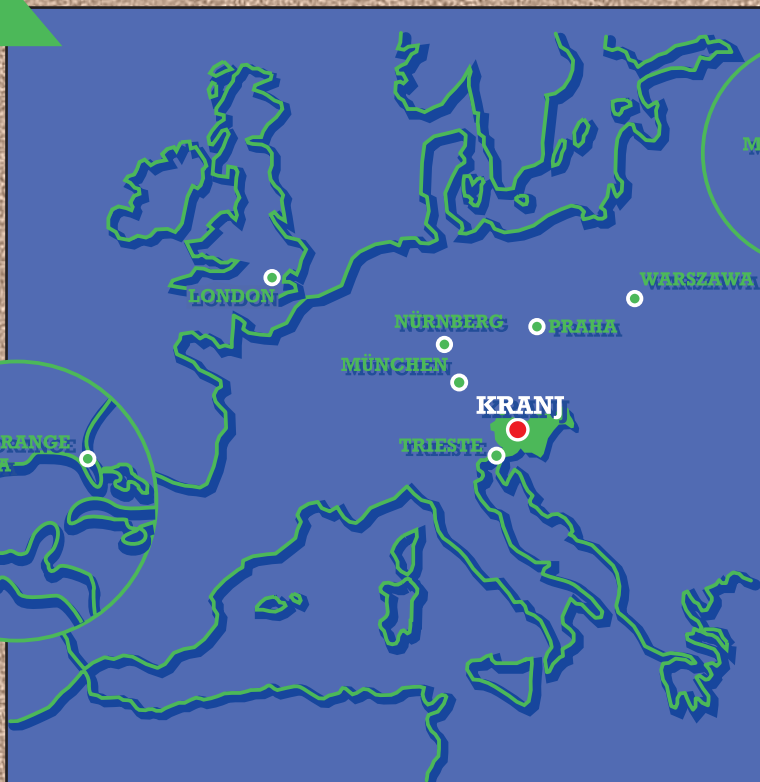

Savatech, d.o.o.
Industrial Rubber Products
and Tyres

The Profiles Programme

Škofjeloška c.6, 4502 Kranj, Slovenia
tel.: + 386 4 206 51 14
fax: + 386 4 206 54 75
<http://www.sava.si/savatech/eng>

Selling agent
Überreicht durch:

Owing to further development we reserve the right to modify data and characteristic of any product. This catalogue should serve just as an orientation; please contact our specialists for any detailed information.

Wir behalten uns das Recht vor die, angegebenen Einsatzdaten und Merkmale durch ständige Weiterentwicklung zu ändern. Dieser Prospekt dient nur zur Orientierung. Für Ihren Einsatzzweck informieren Sie unsere SAVA Techniker gerne.