



OT-Kumi Oy

*Sealing Profiles
Tailored to
Your Needs*

*Asiakaskohtaiset
profiilit tarpeidesi
mukaan*



Sisältö

Puuikkuna- ja ovitiivisteet	6–7
PVC-ikkuna- ja ovitiivisteet	8
Tarratiivisteet lasittamiseen	9
Lasitustiivisteet	9
Alumiini-ikkuna- ja ovitiivisteet	10–13
Teräsovitiivisteet	14–15
Autokoritiivisteet	16–17
Autojen ja koneiden lasitiivisteet	18
U-kumit	19
Letkut	19
Solukuminauhhat EPDM	20
Rakennusteollisuustiivisteet	21
Pantakumit	22
Seulakumit	23
Puskurit	24–25
RAL-värikartta	26
Materiaalit	26
Mittoja, ominaisuuksia sekä toleranssit	27

Contents

Wooden Window And Door Frame Seals	6–7
PVC-Window and Door Frame Seals	8
Tape Seals for Window Glazing	9
Glazing Seals	9
Aluminium Window and Door Frame Seals	10–13
Metal Door Frame Seals	14–15
Autoframe Seals	16–17
Auto and Machine Seals	18
U-Strips	19
Hoses	19
Cellular Rubber Strips EPDM	20
Building Industry Seals	21
Rubber for Steel Band Mounting	22
Sieve Seals	23
Buffers	24–25
RAL Colourmap	26
Materials	26
Measurements, Qualities and Tolerances	27

Hyvä asiakas,

OT-Kumin tiivisteprofileilla TULEE TIIVISTÄ!

Mikä raaka-aine – millainen profiili? Vaihtoehtoja on paljon, mutta niin on käyttötarkoituksiakin sekä ilmastollisia ja ulkoisia vaatimuksia.

Käyttöolosuhteet ratkaisevat - se on kaiken lähtökohta. OT-Kumilla on pitkä kokemus tiivistemateriaaleista, tiivisteprofilien valmistusprosessista ja suunnittelusta. Jaamme tietomme ja osaamisemme asiakkaillemme, kun yhdessä pohdimme parasta tiivisteratkaisua. Lähtökohta muuttuu lopputulokseksi: Tulee tiivistä ja energiaa säästyy!

Pidetään tiivistä yhteyttä!

Dear Customer,

OT-Kumi's sealing profiles guarantees TIGHT SEALING!

What kind of raw material or type of sealing profile do you need? There are a wealth of alternatives to choose from to match different uses and climatic and external requirements. It is the operating conditions that count, because they are the main starting point.

OT-Kumi has extensive experience in sealing materials, the manufacturing process and profile design. We share our know-how and expertise with customers, together considering the best possible sealing solution. With this approach, the starting point becomes the end result: excellent tightness!

Let's keep in touch!

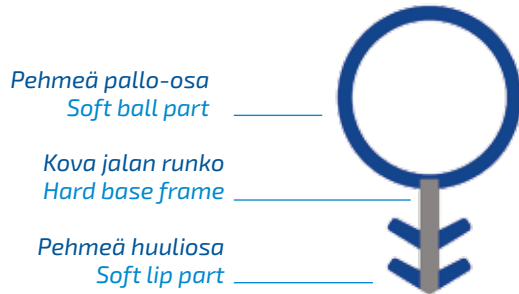

TPE 2-komponenttiprofilin edut

- yksinkertainen ja toimiva rakenne
- kova jalan runko estää venymisen asennettaessa
- pehmeät huulet lukitsevat jalan tiukasti uraan
- hinnaltaan edullinen vaihtoehto
- tiivistää luotettavasti vuosien ajan
- nopea asennettavuus

Advantages of TPE 2-Component Profile

- simple, well-functioning structure
- a hard base frame that prevents elongation on installation
- soft lip parts that lock the base tightly into the groove
- a moderately priced alternative
- a reliable seal that endures for years
- can be installed fast

Jatkuva tuotekehitys – hyvät materiaalit

Pääosa tiivisteprofileistamme suunnitellaan alunperin tiettyyn, tarkasti määriteltyyn kohteeseen. Kokemus on osoittanut, että jo suunnittelun alkuvaiheessa käynnistetty yhteistyö asiakkaamme suunnittelijoiden ja meidän välillä johtaa parhaaseen lopputulokseen.

Standardituotteiden käyttö on vähentynyt ja nykyisin pyritään löytämään profiilin toiminnan kannalta paras ratkaisu. Se voi olla tiiviys, äänenvaimennus, eristyskyky, hinta, värähtelyn poisto tai ulkonäöllinen yksityiskohta. Suulaketyökalut profiileihin valmistetaan tietokoneohjatulla työstökoneella: näin päästään lopputuotteessa erinomaiseen tarkkuuteen.

Ympäristönäkökohdat vaikuttavat yhä enemmän teollisuuden raaka-ainevalintoihin. Kierrätyskelpoisen termoplastisen elastomeerin eli TPE:n osuus onkin kasvanut voimakkaasti viime vuosina.

OT-Kumi Oy on panostanut määrätietoisesti näiden profiilien tuotekehitykseen. Valmistamekin nykyisin tästä materiaalista pääasiassa 2- ja 3-komponenttisyndistelmä profiileja.

Monikomponenttiprofileissa voidaan yhdistää TPE:n eri materiaalien (kova, elastinen, solu) parhaat puolet toimivaksi tiivisteeksi, joka on helppo asentaa ja samalla se on optimaalinen tiivistyksen kannalta. Profiileissa käytetään myös eri värejä. Kovan materiaalin käytöllä estetään venyminen asennettaessa sekä ajan myötä tapahtuva kutistuminen.

TPE-raaka-ainevalikoimassa on myös itsestään sammuvia UL94 VO -luokituksen täyttäviä materiaaleja. Niistä valmistetaan tiivisteprofiileja palo- luokiteltuihin kohteisiin.

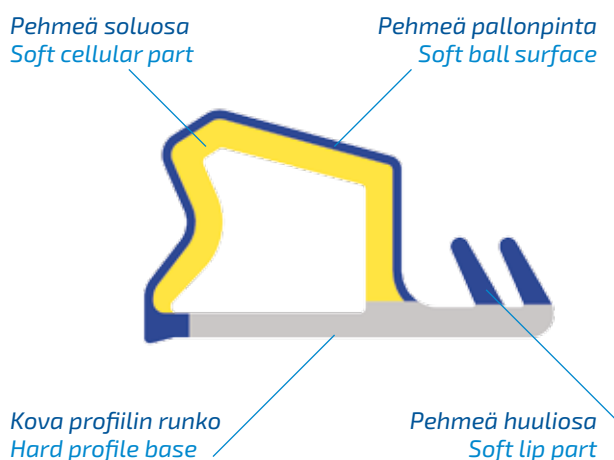

TPE 3-komponenttiprofilien lisäedut

- kevyt ja toimiva rakenne
- tiivistysosan erinomainen palautuvuus myös kylmässä
- hyvä äänieristävyys
- värien yhdistelymahdollisuus samassa profiilissa
- taloudellinen vaihtoehto isoissa erissä

Extra Advantages of TPE 3-Component Profiles

- light, well-functioning structure
- excellent sealing resilience also at low temperatures
- good sound insulation properties
- colour combination possible in the same profile
- economical alternative in big production series

Constant Production Development – High-Quality Materials

Most of our special profiles are designed for a carefully specified purpose. We have learned through experience that the best outcome can be reached by starting co-operation with the customer's designers at an early stage.

Less use is today made of standard products but the emphasis is on looking for the best possible solution to ensure that the profile functions properly. It can be compactness, attenuation property, insulation capacity, price, vibration elimination or a detail in outward appearance. All tools for profiles are made using a computerised machine tool to achieve excellent accuracy in the end product.

Environmental considerations today play important role in industrial raw material choices. As a result, the use of recyclable thermoplastic elastomer, or TPE, in our production has increased

considerably in the last few years. OT-Kumi Oy has been determined to invest in product development work on these profiles. Thus in addition to single-component profiles, we today use TPE in combinations of 2 and 3 components.

With multi-component profiles, the various TPE hardnesses and the best properties of foamed material can be combined into a product which can be installed easily and which represents the ultimate in sealing. Profiles can also be made in different colours while the use of hard material allows prevention of elongation on installation and also any subsequent shrinking.

The broad range of TPE raw materials available also includes self-extinguishing materials that conform with the UL94 VO classification and that can be used for making sealing profiles for use in targets critical in terms fire safety.

6 / *Puuikkuna- ja ovitiivisteet*
Wooden Window And Door Frame Seals

101

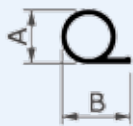

A 6 7 10 12
B 9 9 14 16

101R

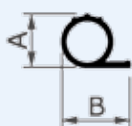

A 6 7 10 12
B 9 9 14 16

104

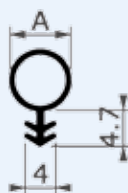

A 6 7 8 10

104R

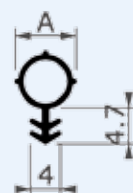

A 6 7 8 10

114

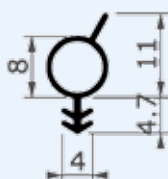

118

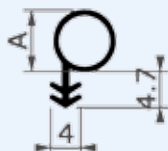

A 6 7 8 10

118R

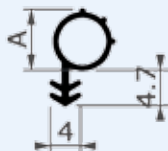

A 6 7 8 10

104E

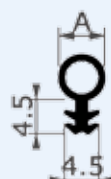

A 6 8 10

4214

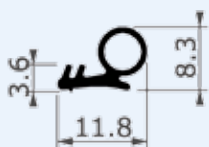

4974

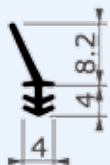

5200

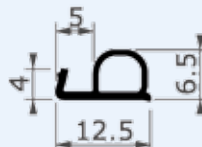

5472

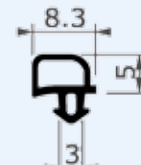

6030



6141

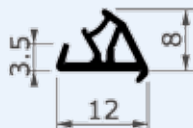

5341

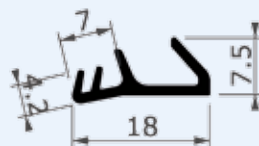

6353

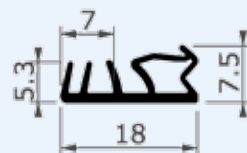

6354



6881



6900

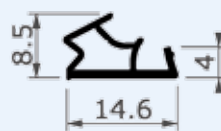

130

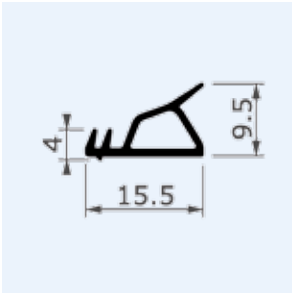

5058

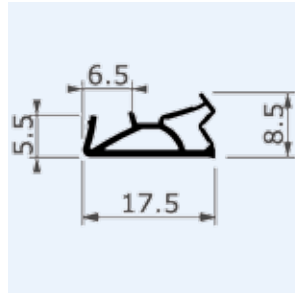

5550

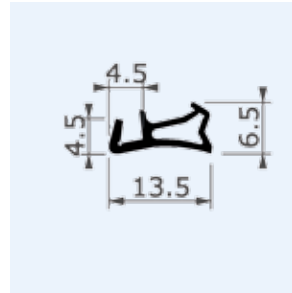

5554

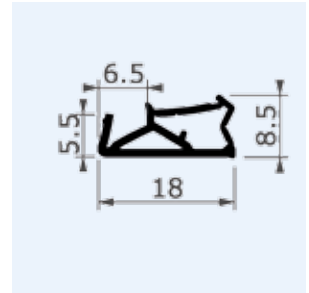

5657

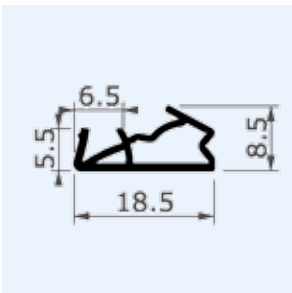

5728

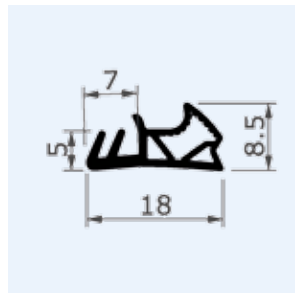

5929

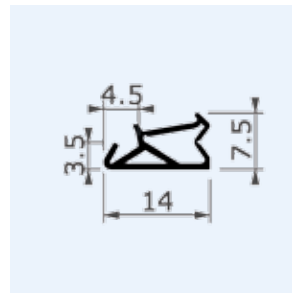

6049

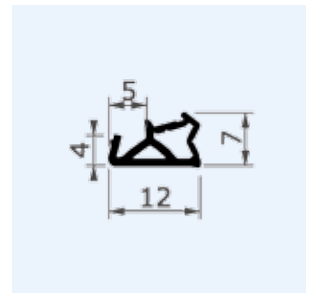

6050

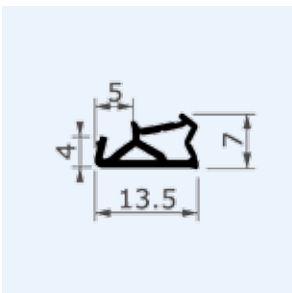

6193

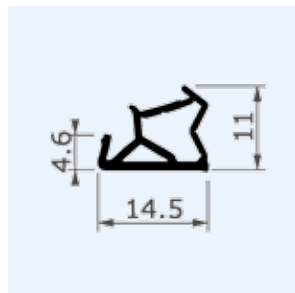

5793

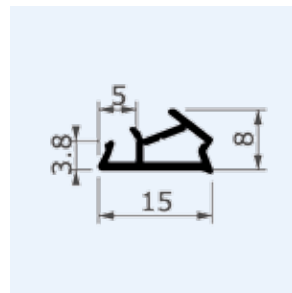

5658

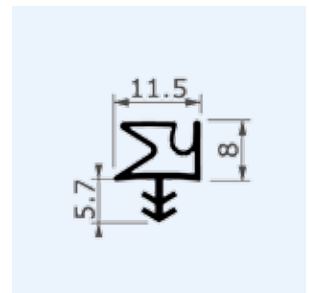

5659

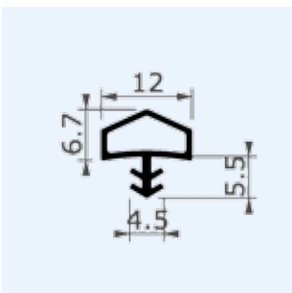

5659a

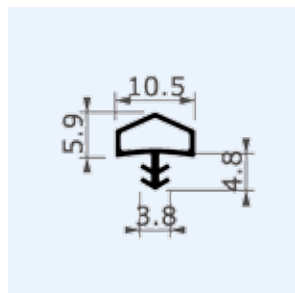

5660

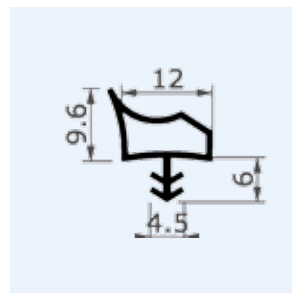

5603

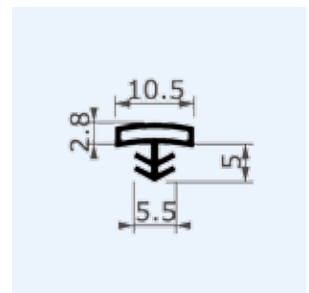

6319

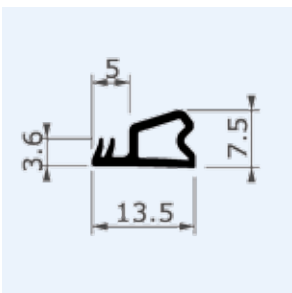

6700

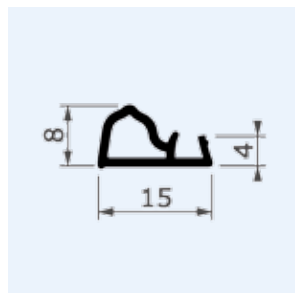

6690

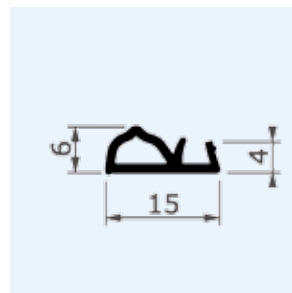

6875

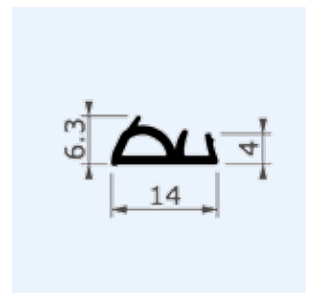

4501

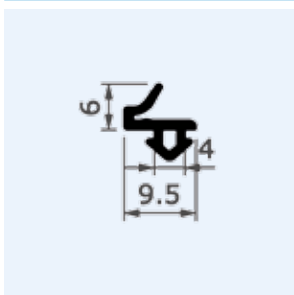

4513

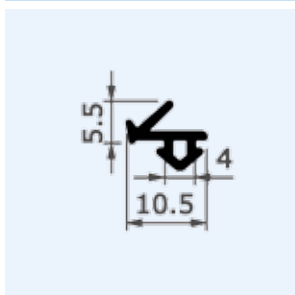

5619

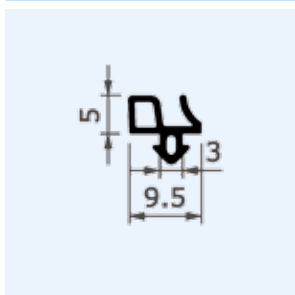

5620

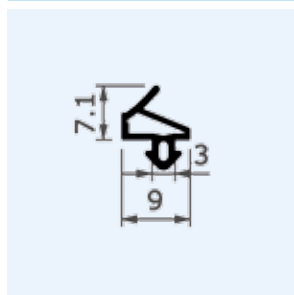

5638

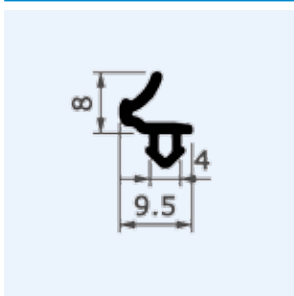

5639

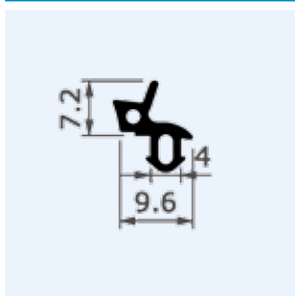

5992

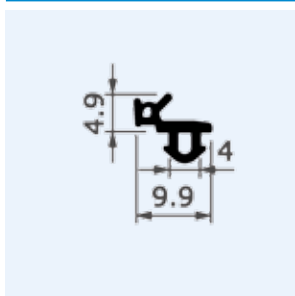

6014

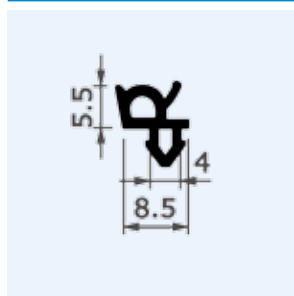

6015

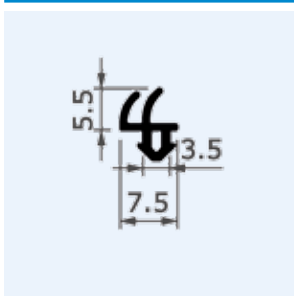

6173

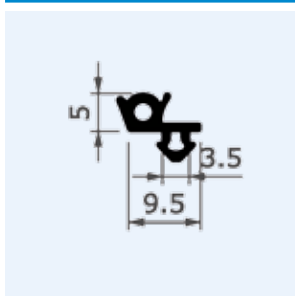

6174

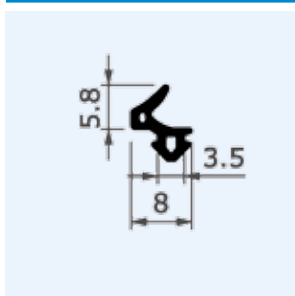

6175

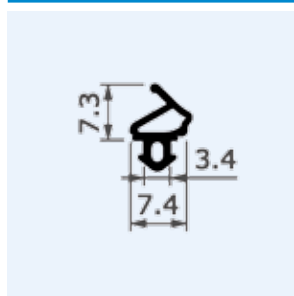

6176

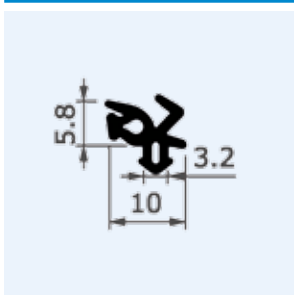

7486

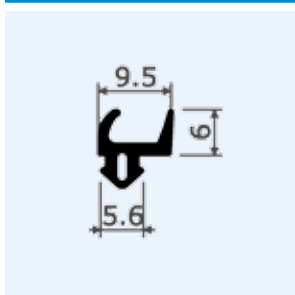

7487

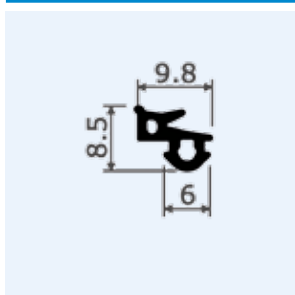

7488

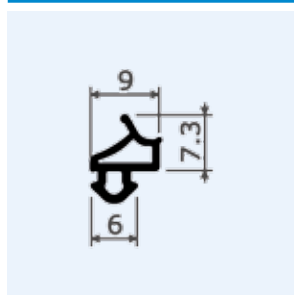

4111

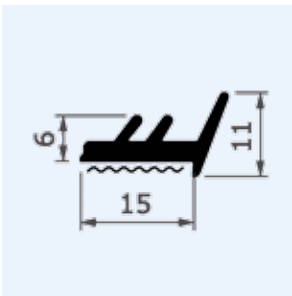

4119

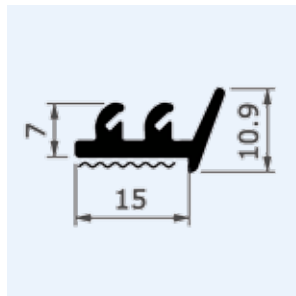

4302

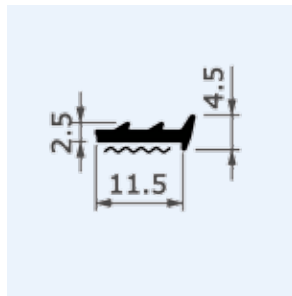

6256

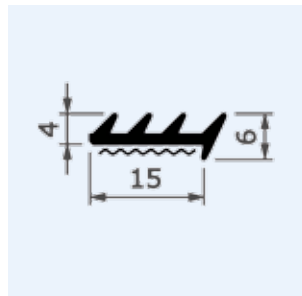

6266

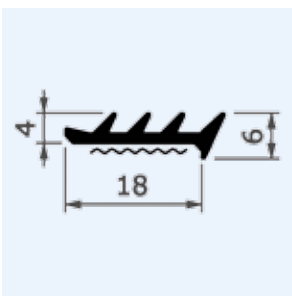

Lasitustiivisteet
 Glazing Seals

4903

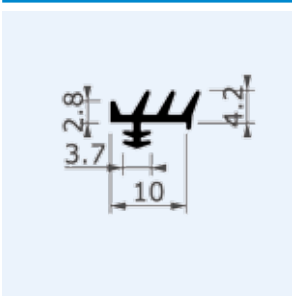

6215

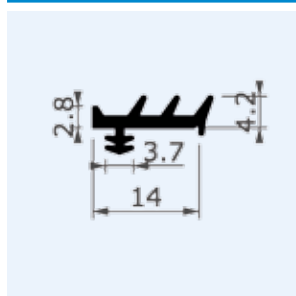

6223

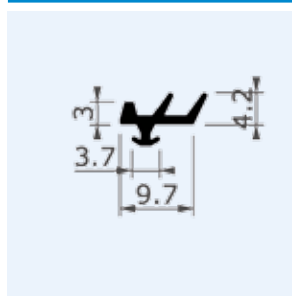

7574

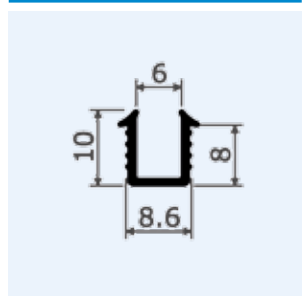

5831

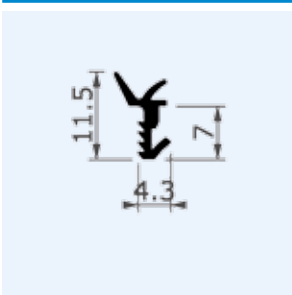

5014

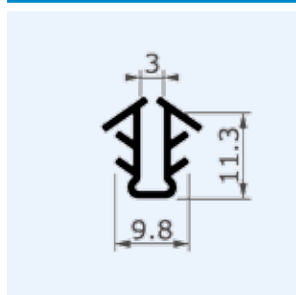

5751

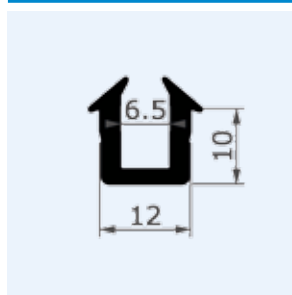

5834

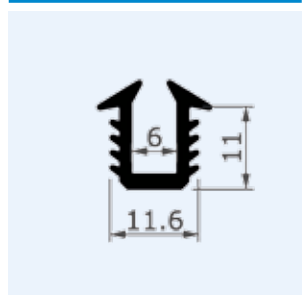

5835

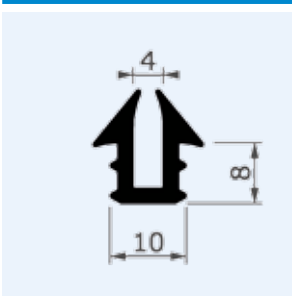

5872

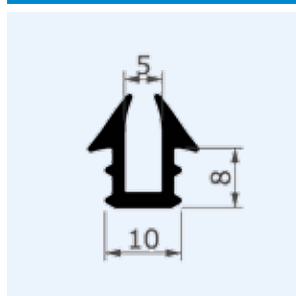

4244

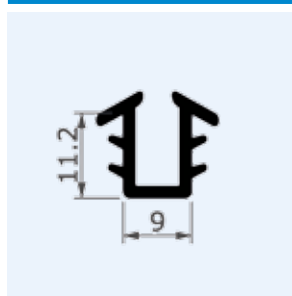

6852

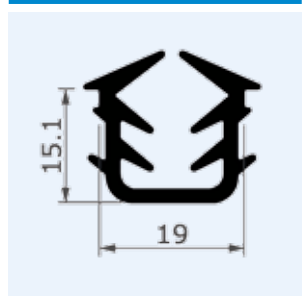

1044 PX3

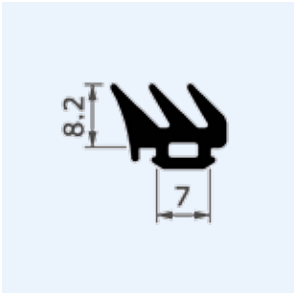

1045 RT25

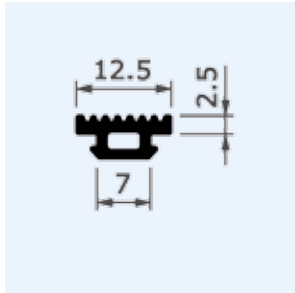

1046 RT50

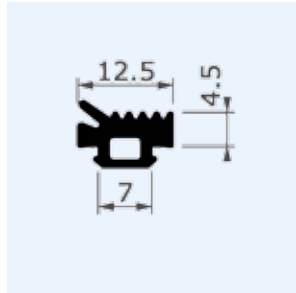

1048 RT120

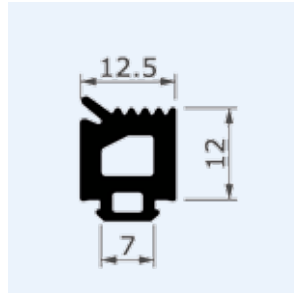

1060 RT30

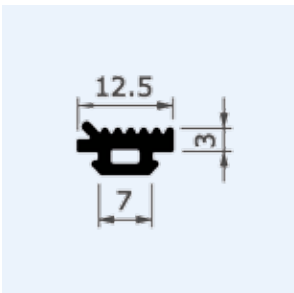

4019 PT5

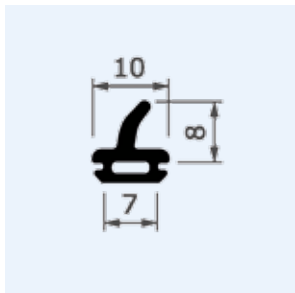

4020 ET2

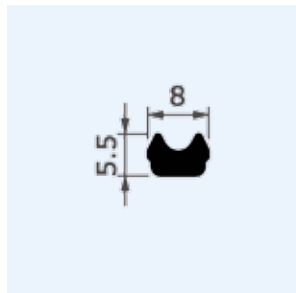

4027 PT3

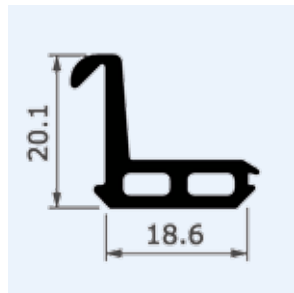

4028 DX919

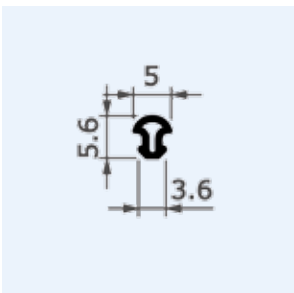

4029 DX819

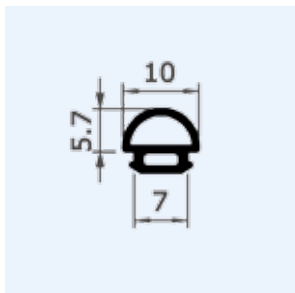

4030 PX1

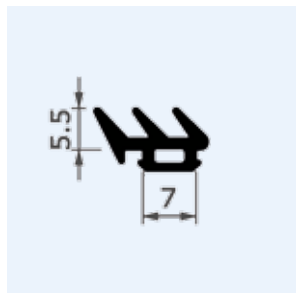

4031 PX4

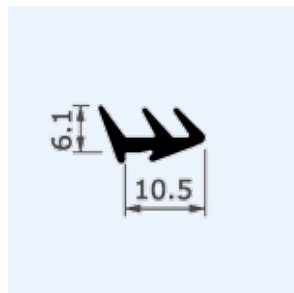

4031L

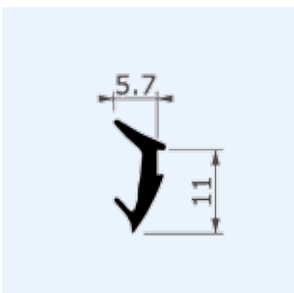

4081 PX5

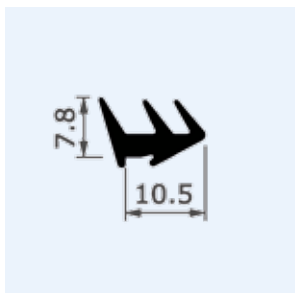

4082 PX2

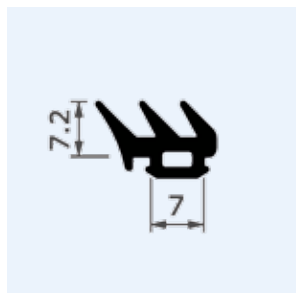

4086 DX818

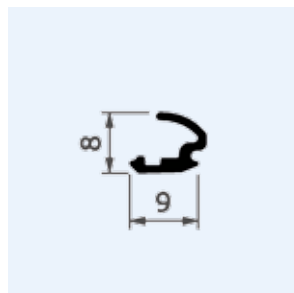

4089 VT4

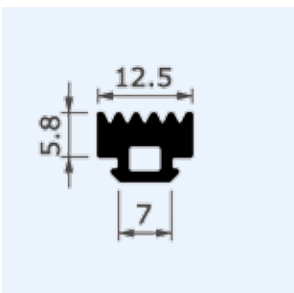

4090 SG1

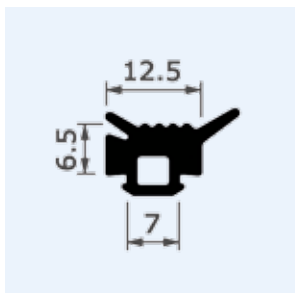

5253 LOT1

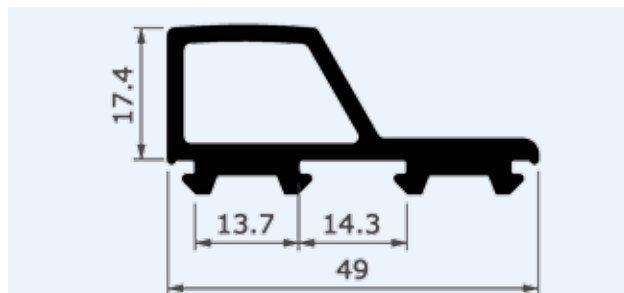

5509 SG2

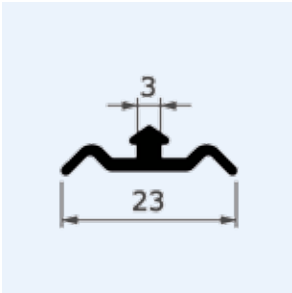

5674 DX819-4

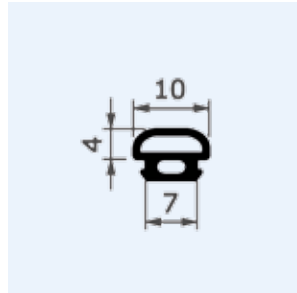

5790 SG4

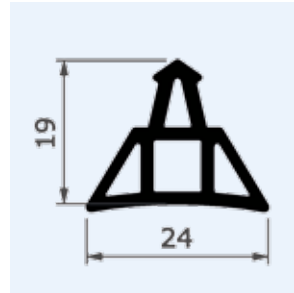

5845 ET3

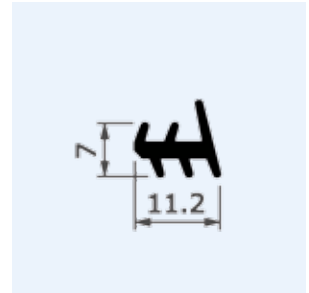

5982 DX815

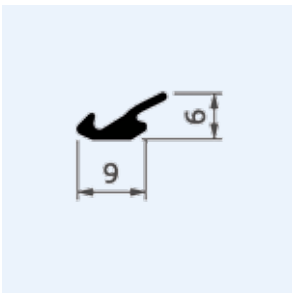

5946 DX819-8

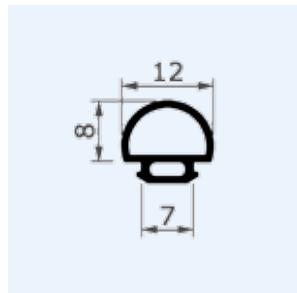

6501 DX731

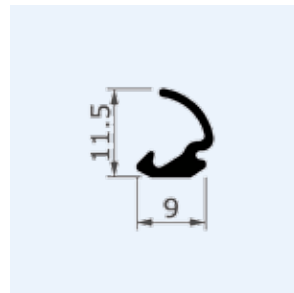

6502 DX732

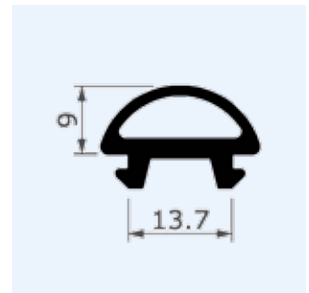

6503 DX733

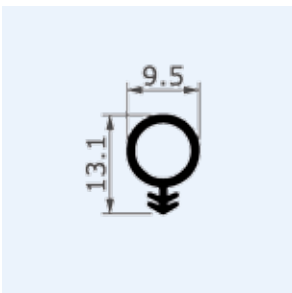

6504 ET4

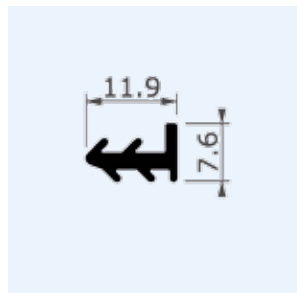

6505 IT511

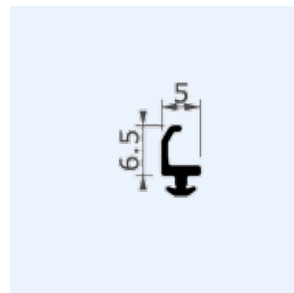

6506 PT10

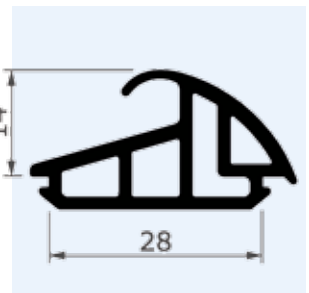

6507 PX10

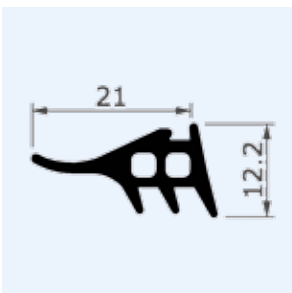

6508 PT6

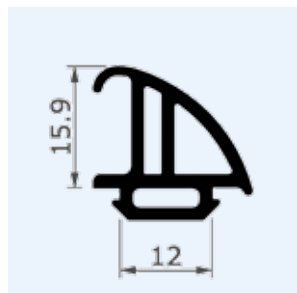

6509 KT1

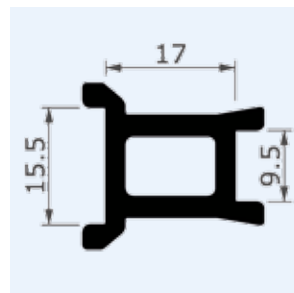

6510 IT521

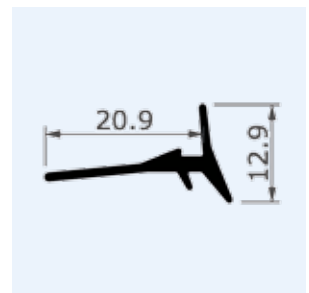

6511 IT501

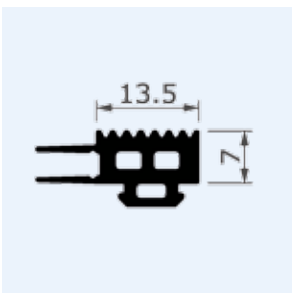

6512 K922

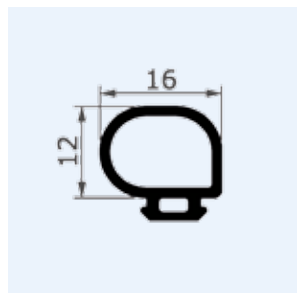

6513 K923

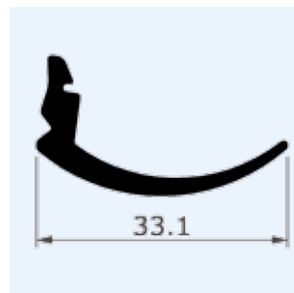

12 / *Alumiini-ikkuna- ja ovitiivisteet*
Aluminium Window and Door Frame Seals

6515 RT45

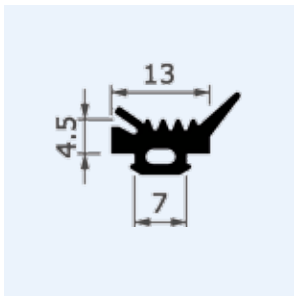

6516 RT80

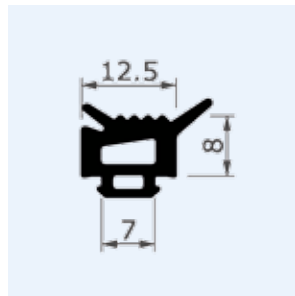

6517 K1041

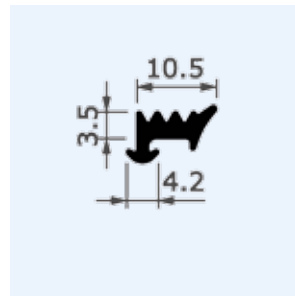

6519 K-1347

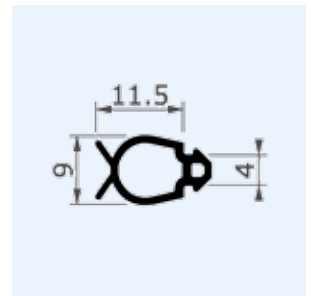

6520 VT12

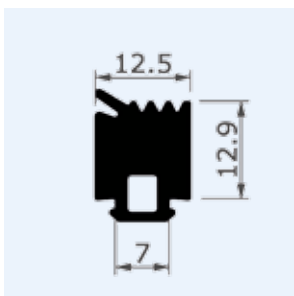

6521 DX30

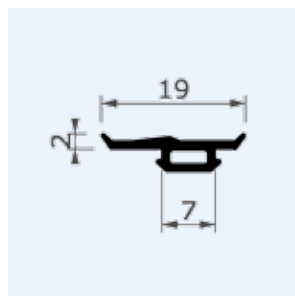

6522 RTSLE

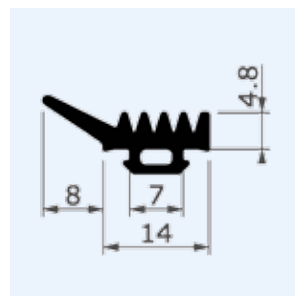

6523 LOT3

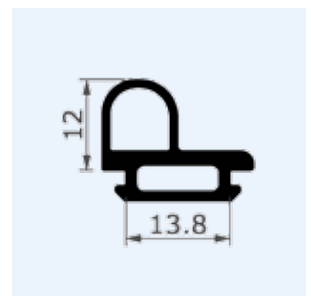

6524 ET200

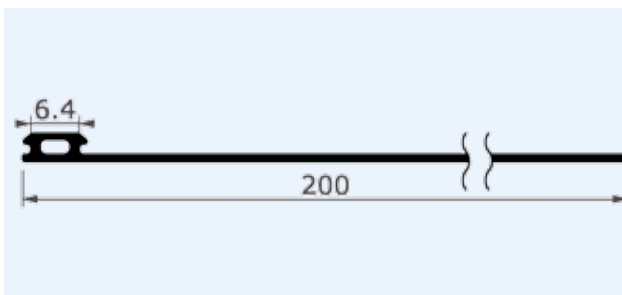

6525 K-1607

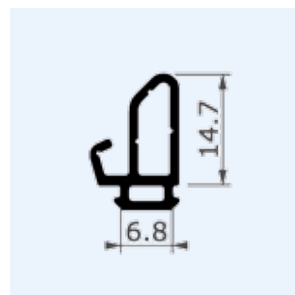

6588 6001

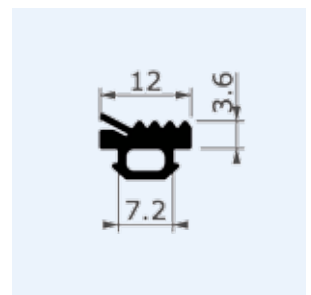

6586 301

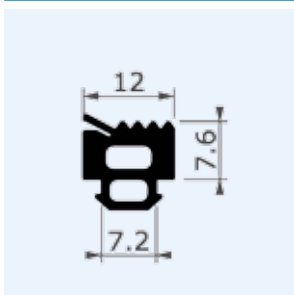

6589 6002

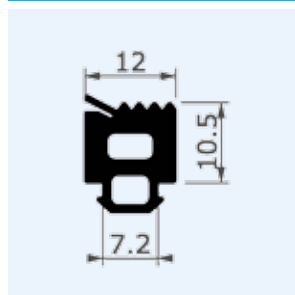

6587 007mm

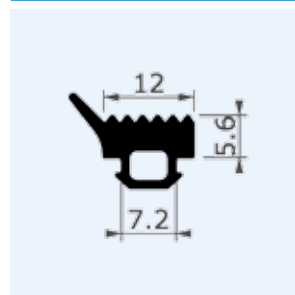

6585 005 - 01

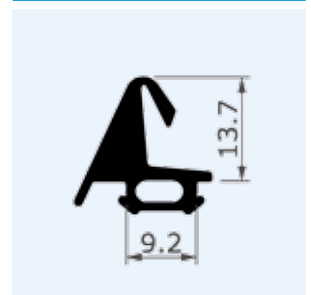

6591 66015

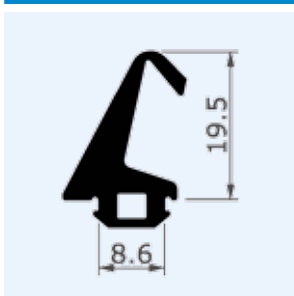

6590 6005

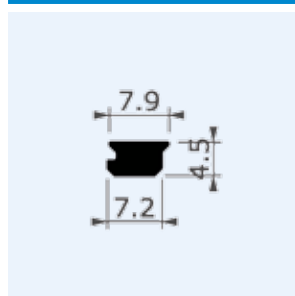

4612 612

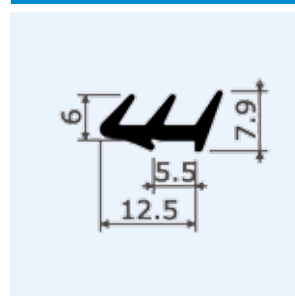

6250

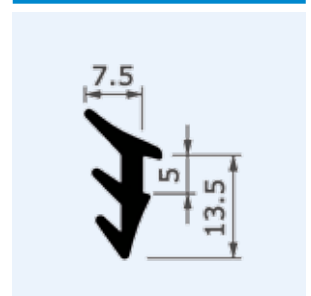

4611 611

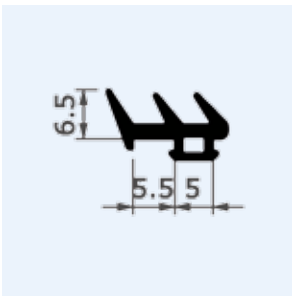

4619 619

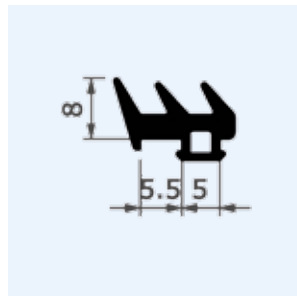

4638

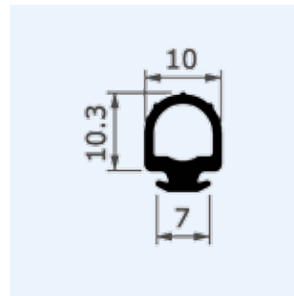

5252 TL50

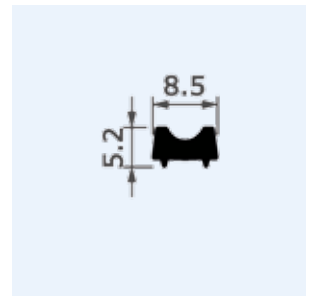

7477

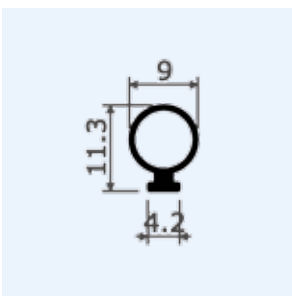

6579 TJL

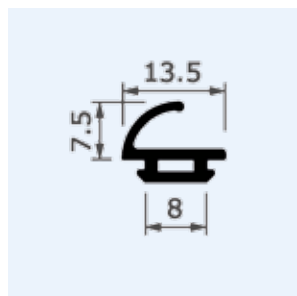

6570 U5

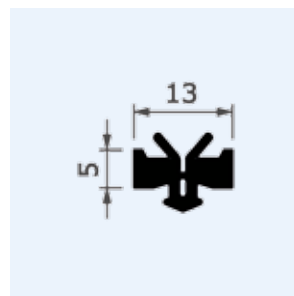

6571 V3

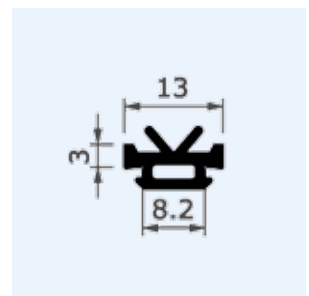

6572 VS

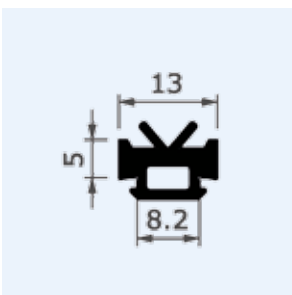

6573 V7

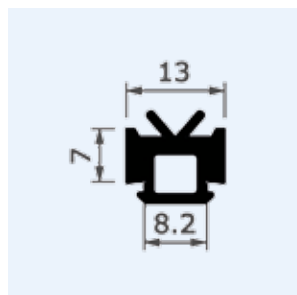

5632 V7 RGM 1

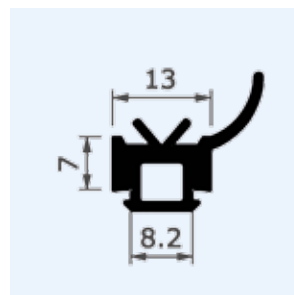

6529

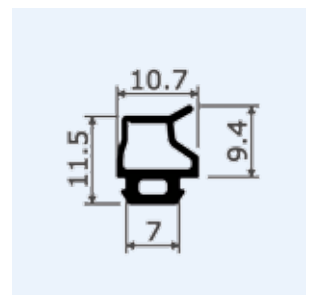

6534

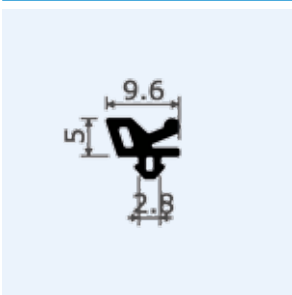

6535

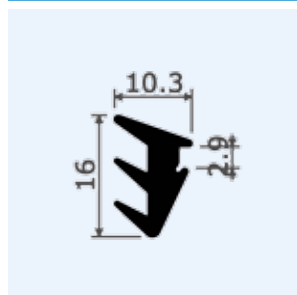

6536

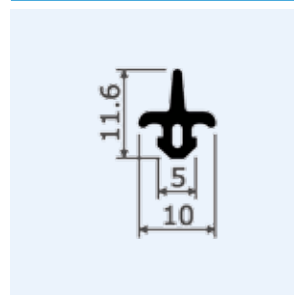

6537

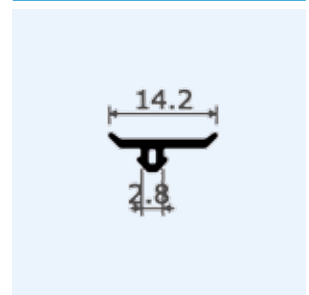

6577 P50

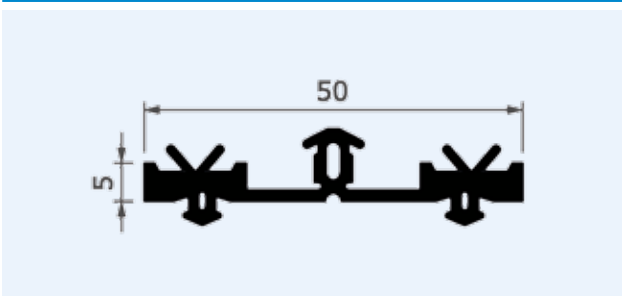

6578 V50

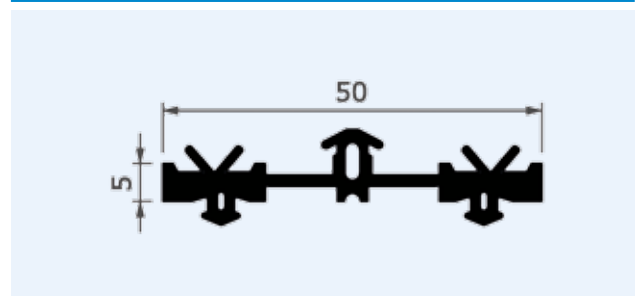

1095

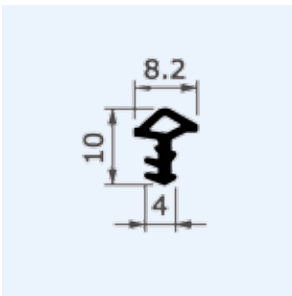

1096

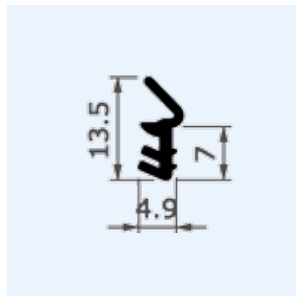

5322

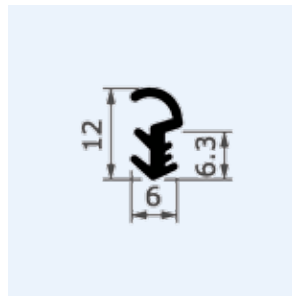

4058

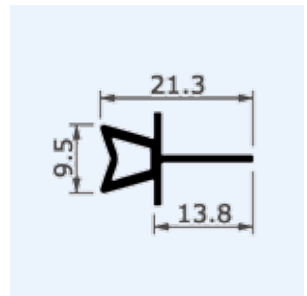

4061

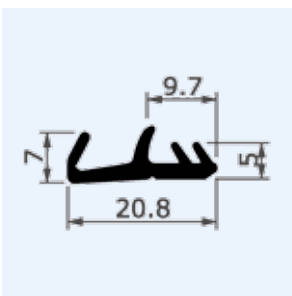

4062

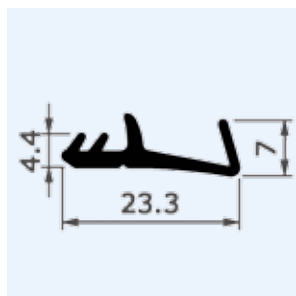

5612

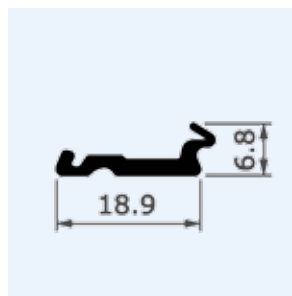

5613

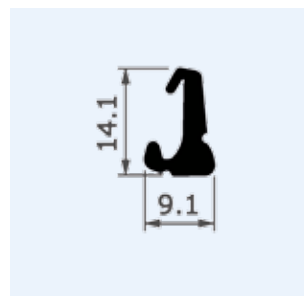

2035

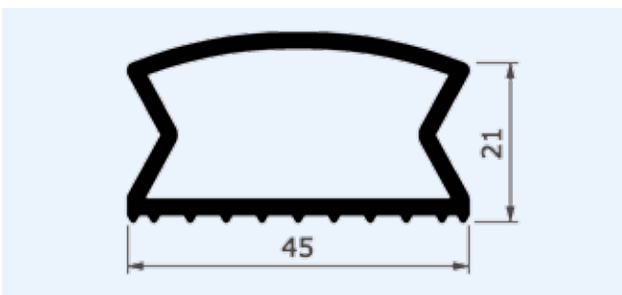

4305

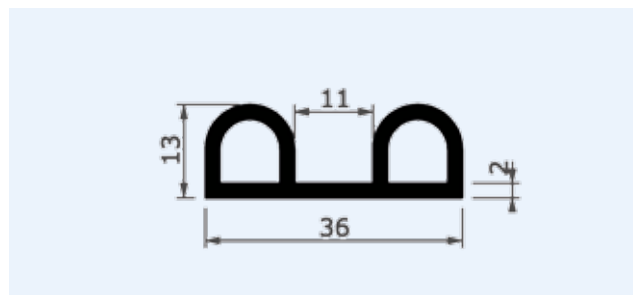

4322

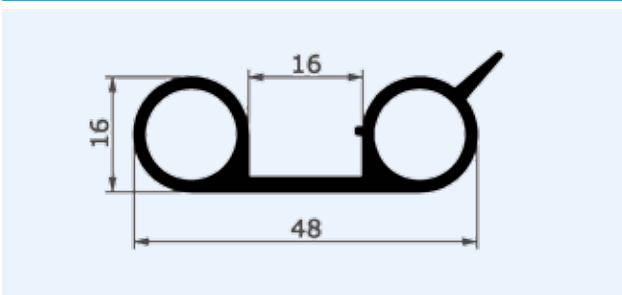

4584

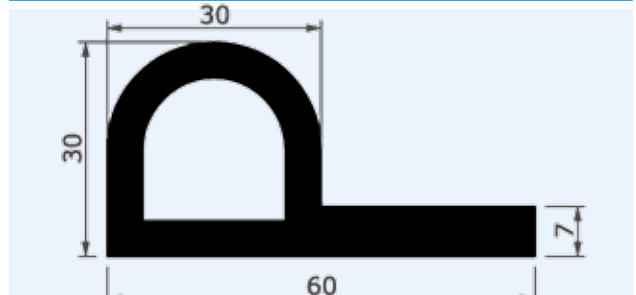

5724

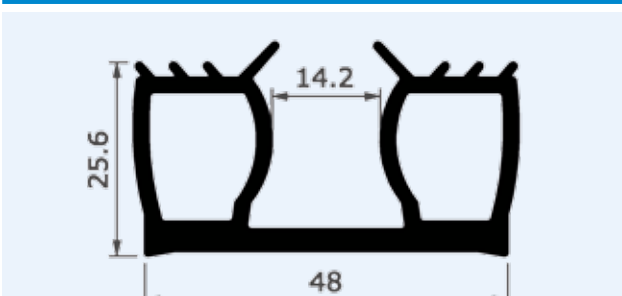

5725

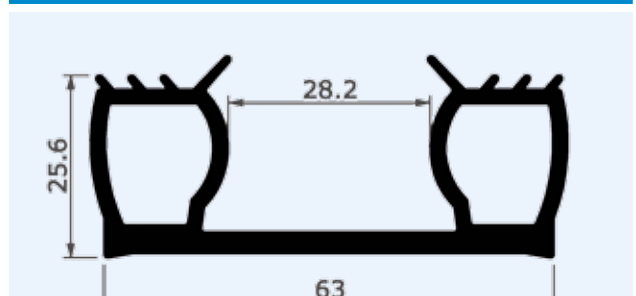

4428

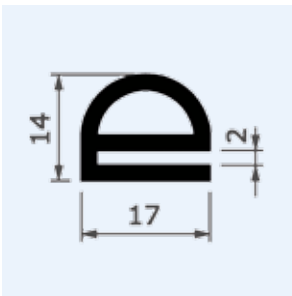

5549

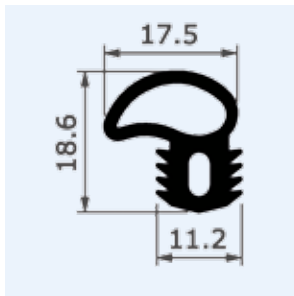

5692

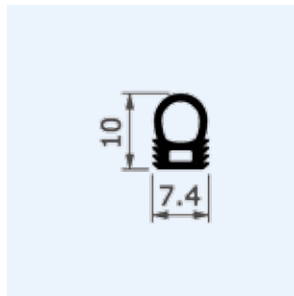

6043

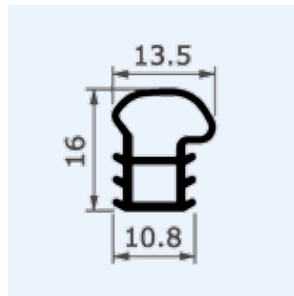

6062

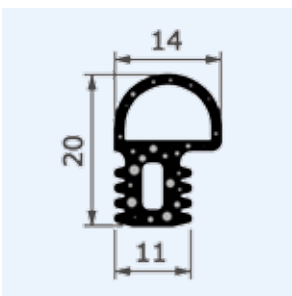

6064

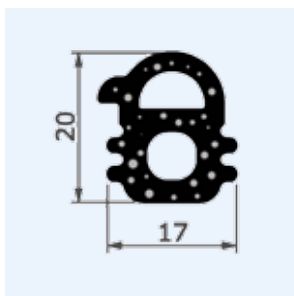

6139

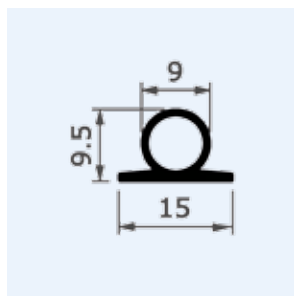

5718

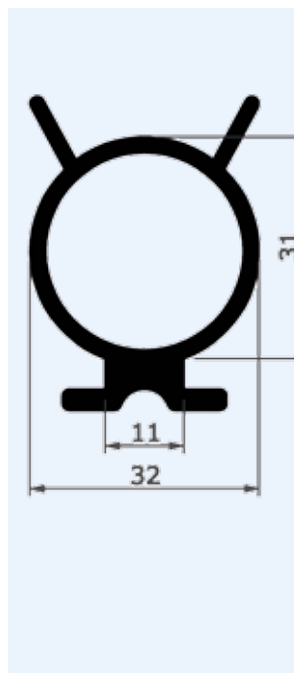

5635

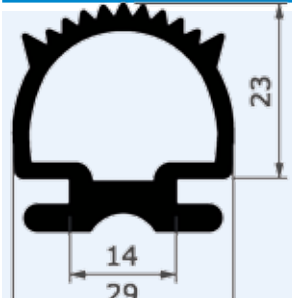

4294

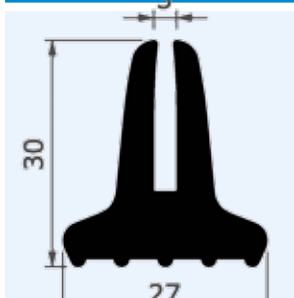

6079

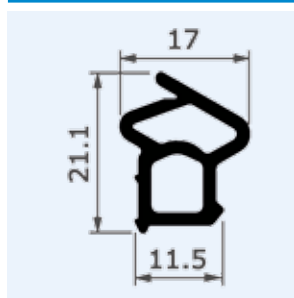

4200

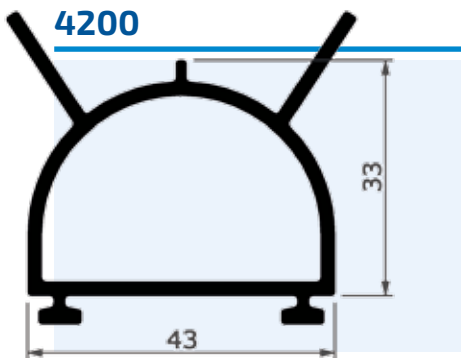

7311

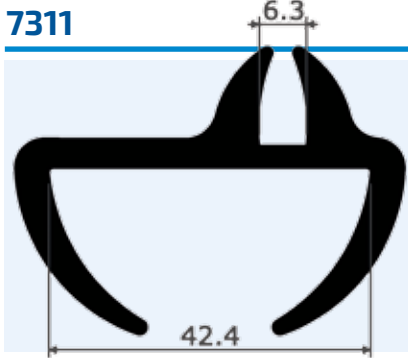

5884

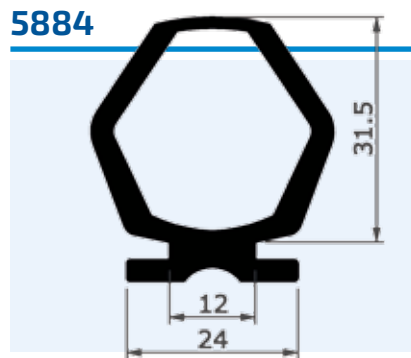

5892

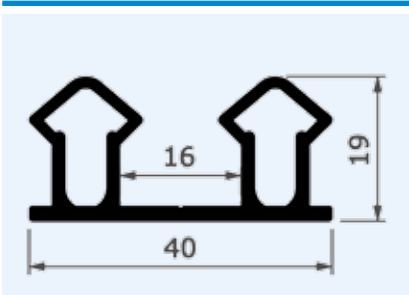

4345

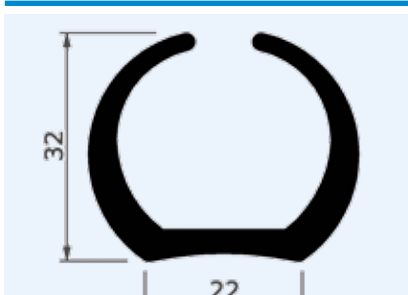

6787

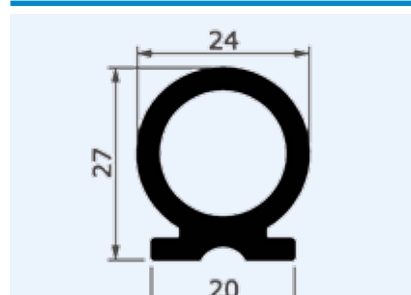

4109

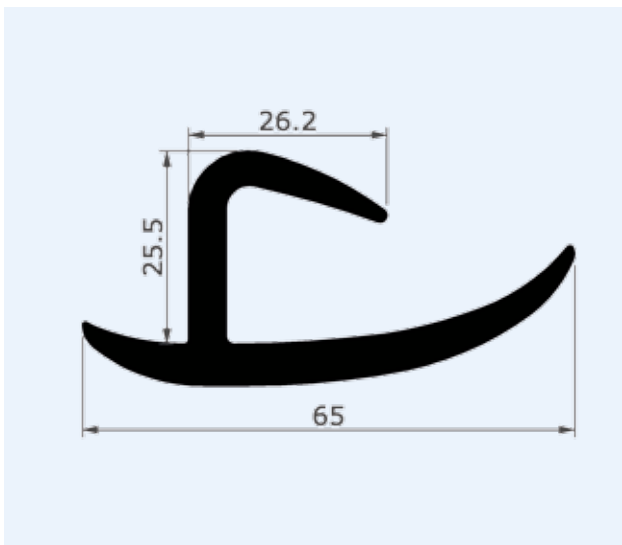

4245

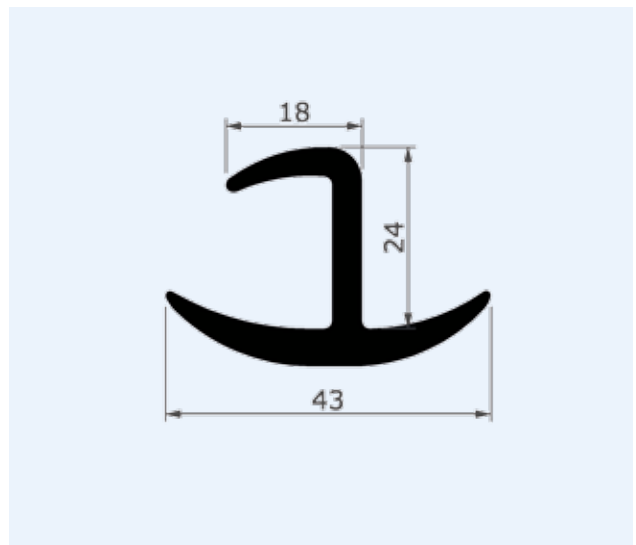

4057

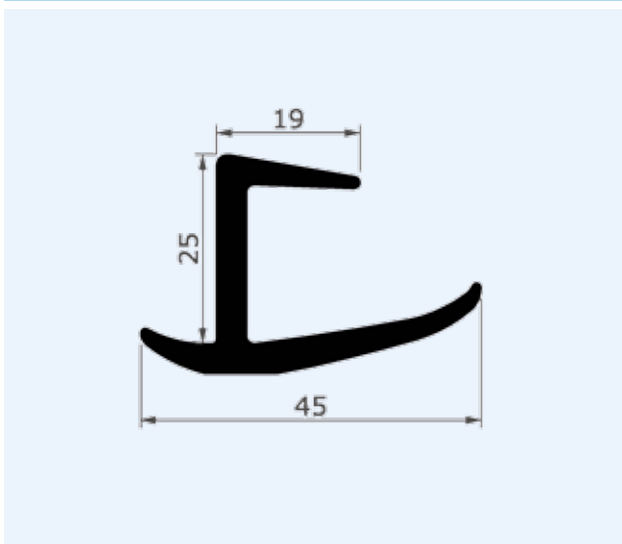

6059

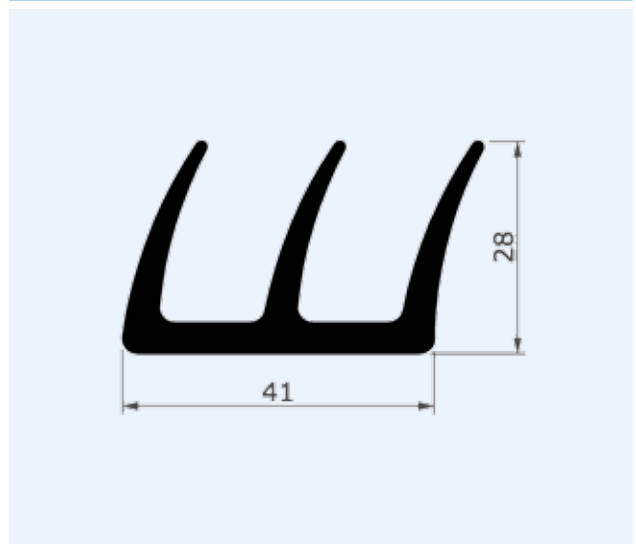

4056

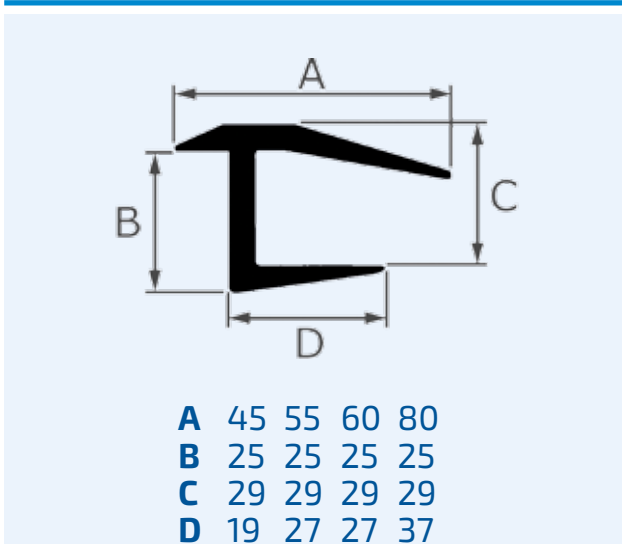

4108

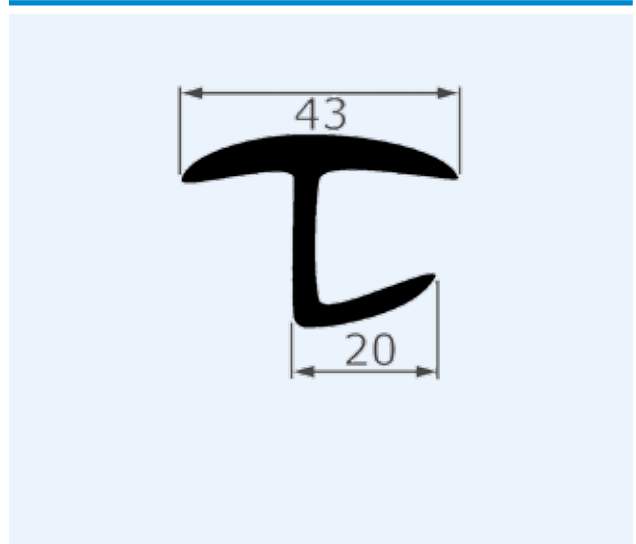

4110

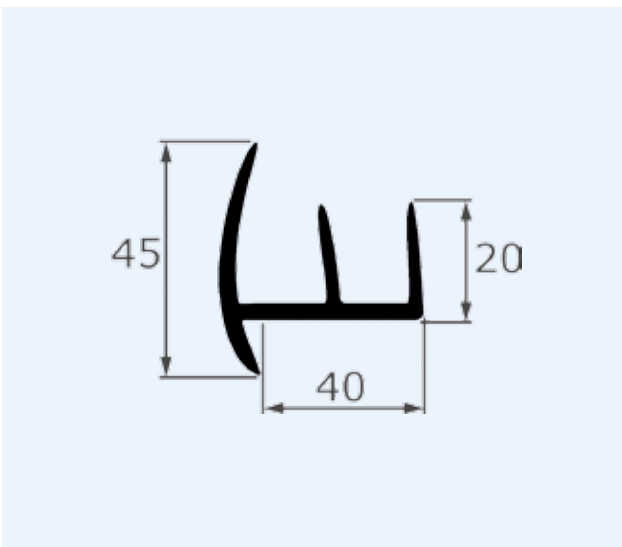

4223

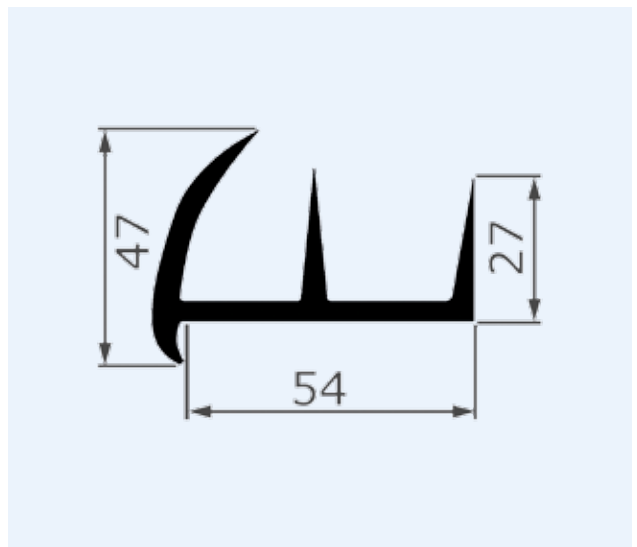

4786

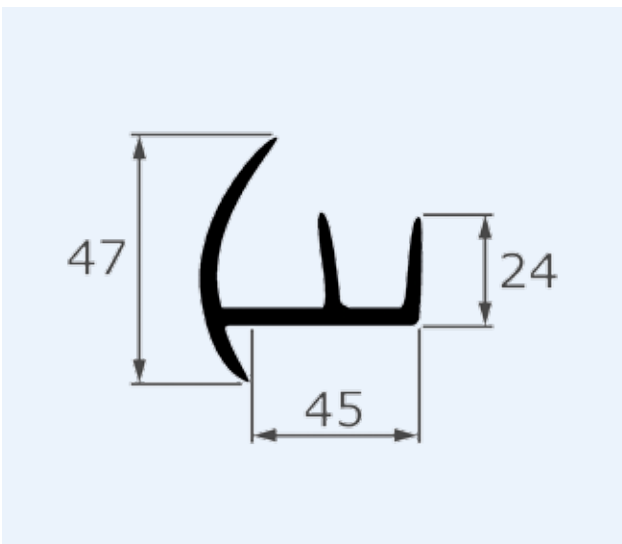

4892

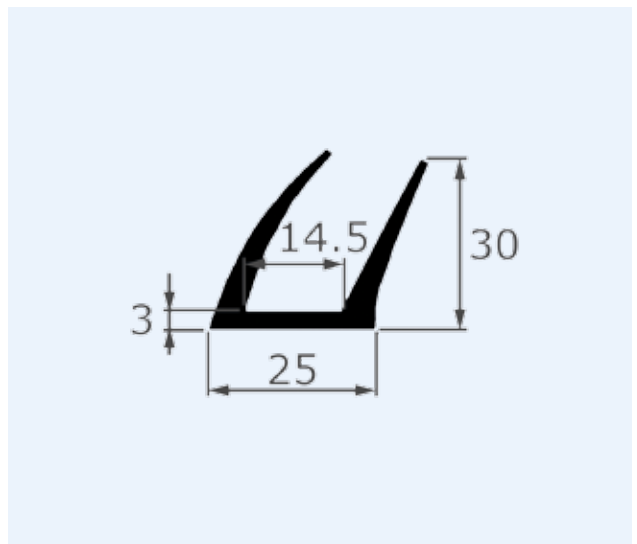

4165

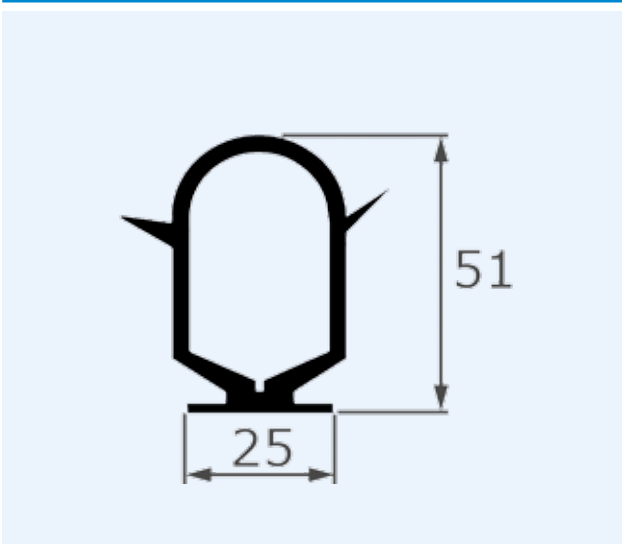

4186

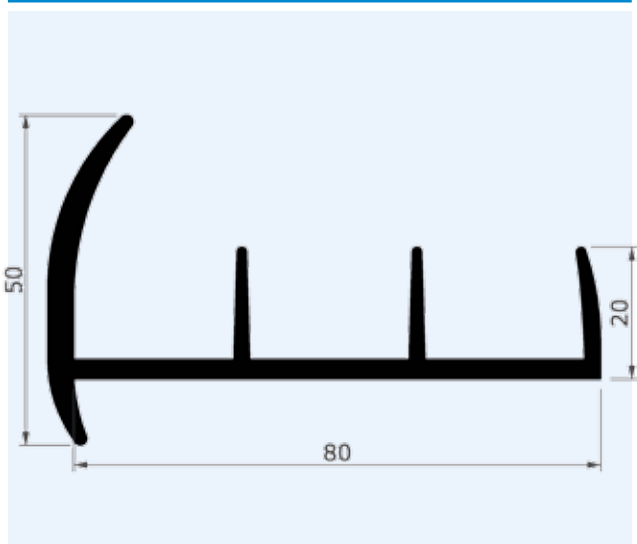

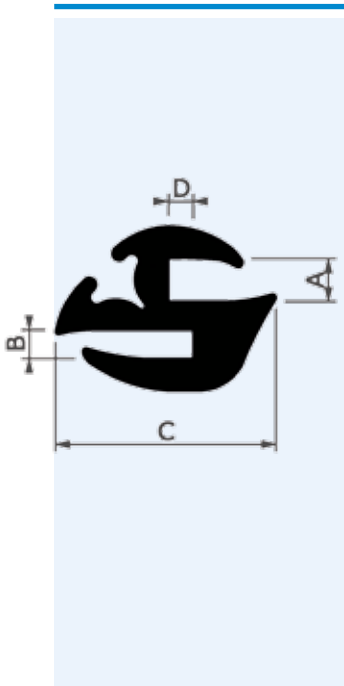

	A	B	C	D
4242	5	4	31	5
4271	5	8	31.5	5
4268	5	10	32	5
4269	5	12	32	6
4270	5	15	35	
4389	10	6	32	
4323	15	5	26	5
4436	17	10		
4793	6	3	31	5
4878	6	30	50	10
5047	6	20	40	8
5066	20	6		8
5100	4-5	5-6		5
5210	5	60		6
5298	6	5		5

	A	B	C	D
5314	8	20		8
5317	8	17		6
5331	4	17		6
5377	11.5	23		10
5390	6	5	31	
5407	8	5		5
5483	13	6		5
5504	15	7		
5673	6	4	31	5
6299	10	3	32	6
6386	10	23	35	10
6387	10	32	35	10
6623	6	25	35	10
6692	5	2	27	5

4241

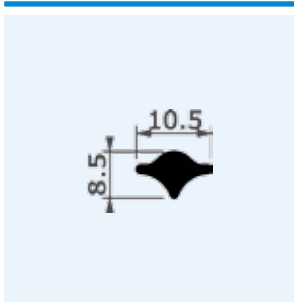

6946

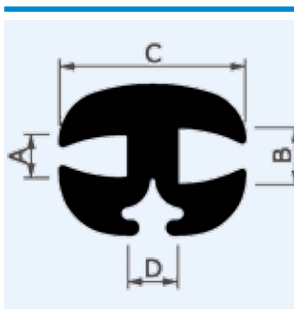
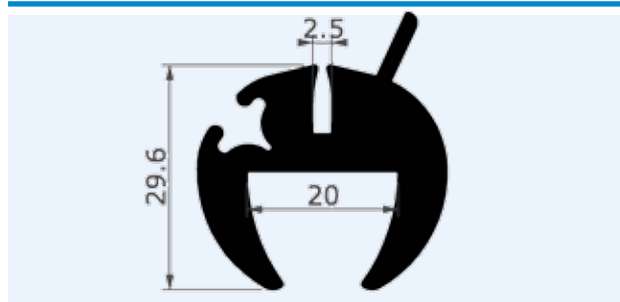

	A	B	C	D
4138	6	3	26	
4188	6	2	26	
4217	4	2	26	
4534	12	6	30	
4273	5	5	26	
4599	5	2.5	21	
5097	4.5	2.5	26	
5282	10	3	25	

	A	B	C	D
5344	5	20	29	
5346	5	18	26	
5356	8	6	26	7
5501	5	25	27	
5544	5	52	29	
5810	6	8	26	
6681	4	11	26	6
6920	6	6	26	7

	A	B	C
4007	13	12	8
4233	18	32	13
4240	18	10	12
4267	3	5	1.5
4346	23	15	15
4420	5	9	2
4466	13	12	6
4592	16	19	10
4593	6	7	3
4594	8	12	4
4595	9	12	5
4596	8	12	6
4704	23	30	18
4705	5	7	1
5078	22	15	16
5085	34	15	20
5089	50	40	30
5090	48	40	28
5109	11	15	8
5124	61	53	50
5223	10	10	7
5242	8	12	3

	A	B	C
5286	14	18	12
5312	15	12	11
5357	25	22	16
5394	22	20	16
5542	20	15	12
5583	12.5	10	10
5587	16	20	12
5595	22	25	15
5602	20	14	16
5697	10.5	15.5	7.5
5715	6	9.5	3
6024	6	12	3
6048	6	18	3
6089	10	12	6
6205	18	25	12
6242	20	20	9
6243	25	25	13
6251	16	20	9
6252	21	25	13
6383	10	10	6
6482	12	17	9

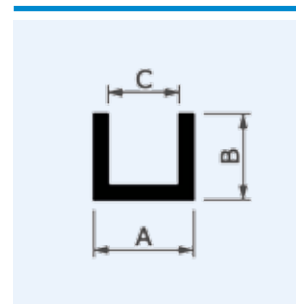

Letkut Hoses

Asiakkaan mittojen mukaan
Made to customer's order

Esim. / Examples

A	2	3.5	6	10	24	30
B	6	6.5	12	12	35	40



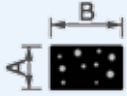

Asiakkaan mittojen mukaan
Made to customer's order

Esim. / Examples

A 2 7 30 45
B 8 11 80 100

O-Rengasnauha / O-Ring strip



Asiakkaan mittojen mukaan
Made to customer's order

Esim. / Examples

4 – 30

Pohjanauha / Strip

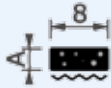

Värit: valkoinen, musta
Colours: white, black

A 2 3 4 5

P-Tiiviste / P-Seals

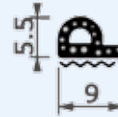

Värit: valkoinen, musta,
ruskea
Colours: white, black,
brown

E-Tiiviste / E-Seals

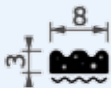

Värit: valkoinen, musta,
ruskea
Colours: white, black,
brown

4227

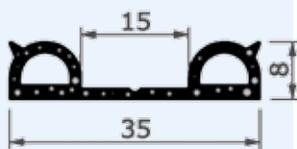

5670

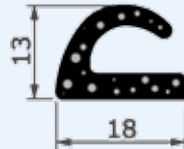

5721

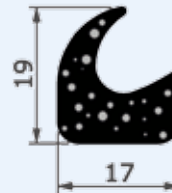

6090

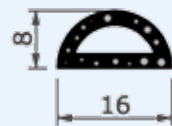

4815



6605

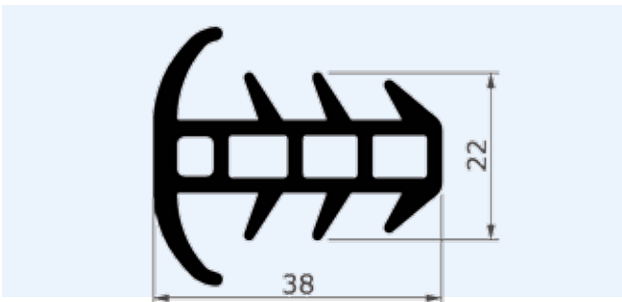

	<i>Sauman leveys mm</i>
	<i>Width of groove mm</i>
4177	8 - 13
4178	13 - 19
4179	19 - 26
4532	26 - 35

6671

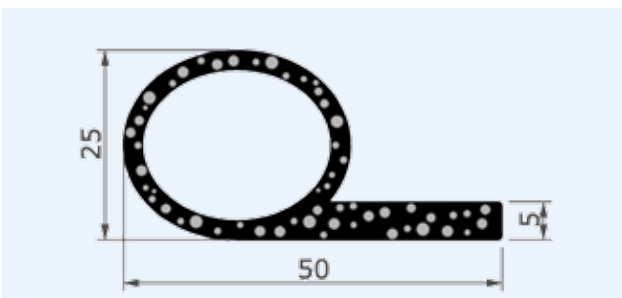

5360

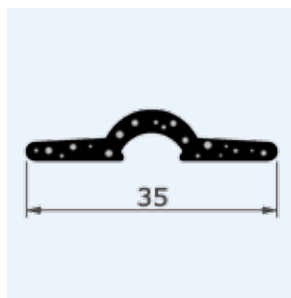

4676

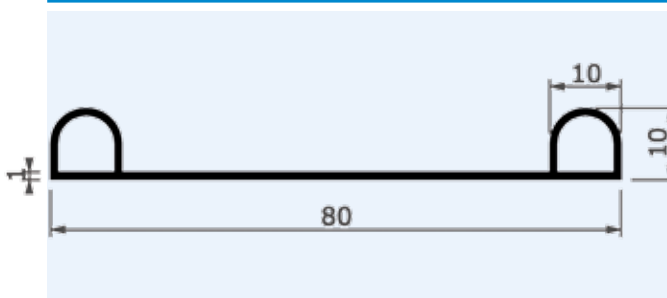

74021

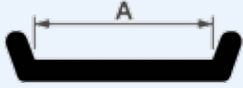

A 25 35 45 55

5998

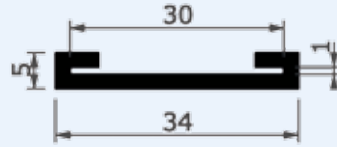

5999

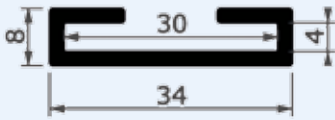

7629

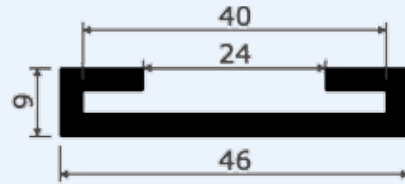

6262

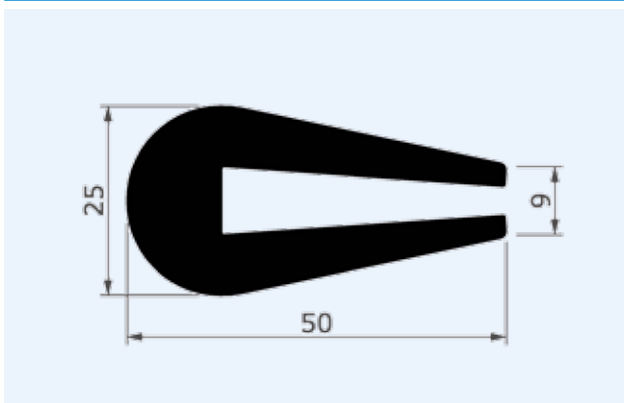

4317

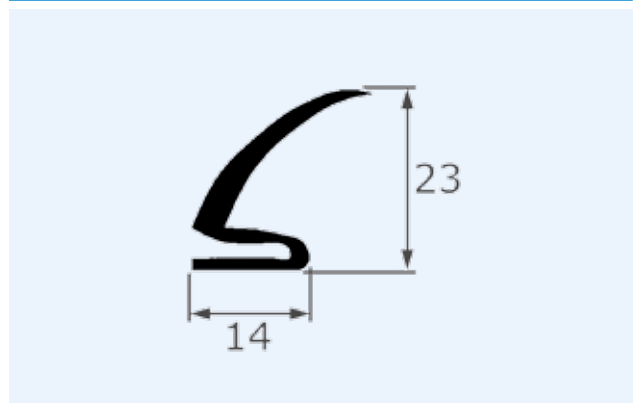

4189

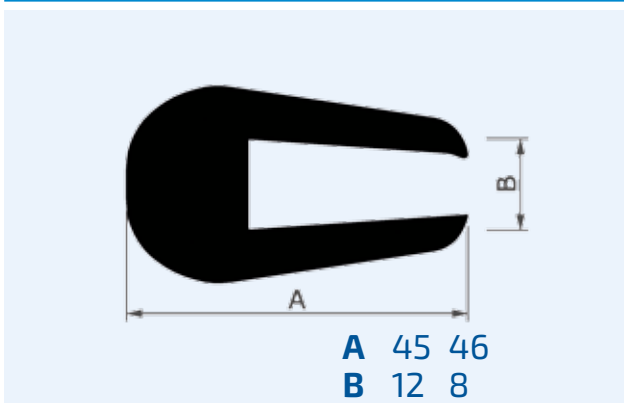

7619

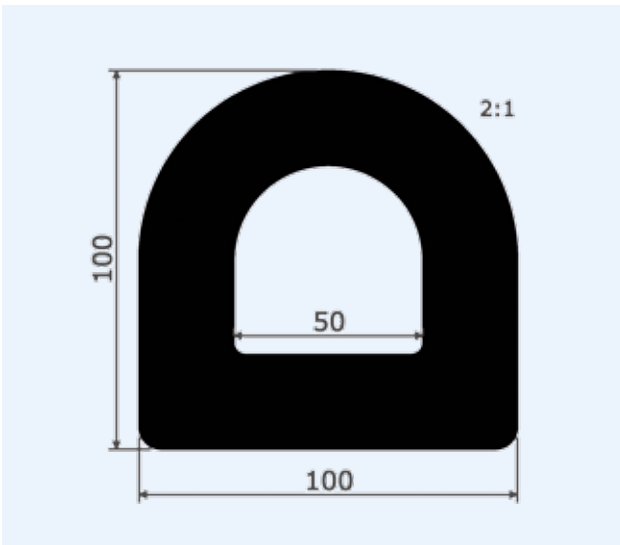

7188

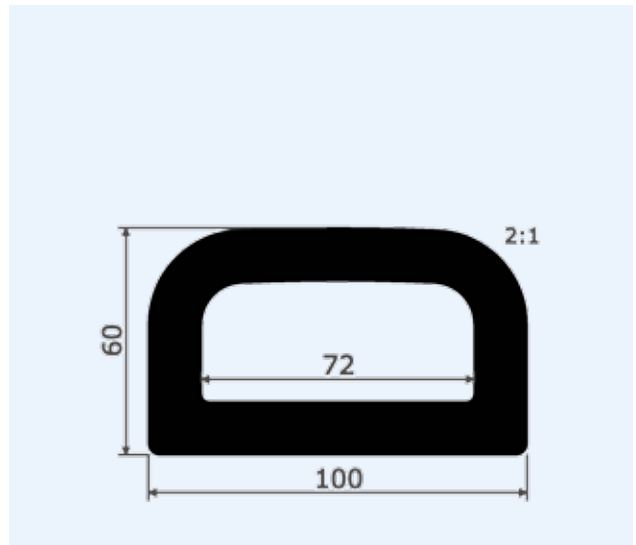

5823

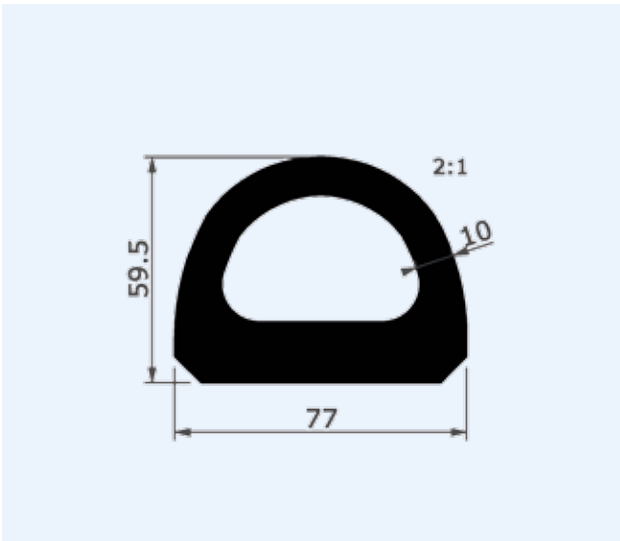

5577

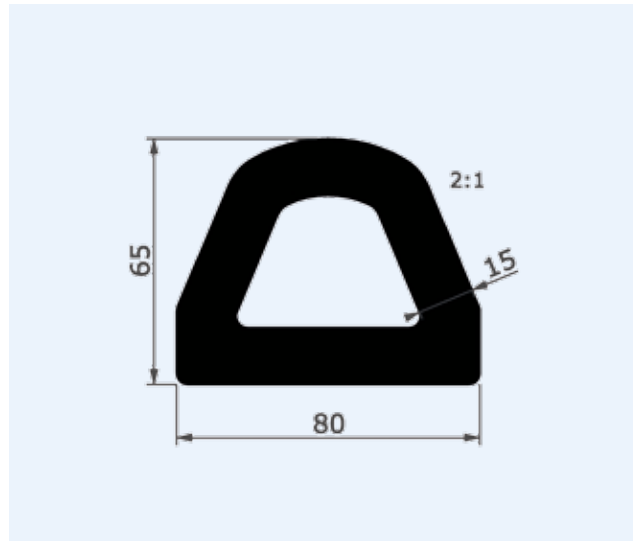

17006

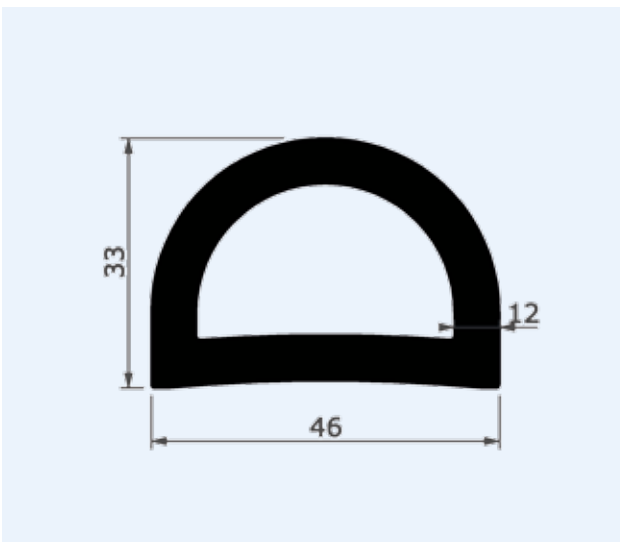

5106

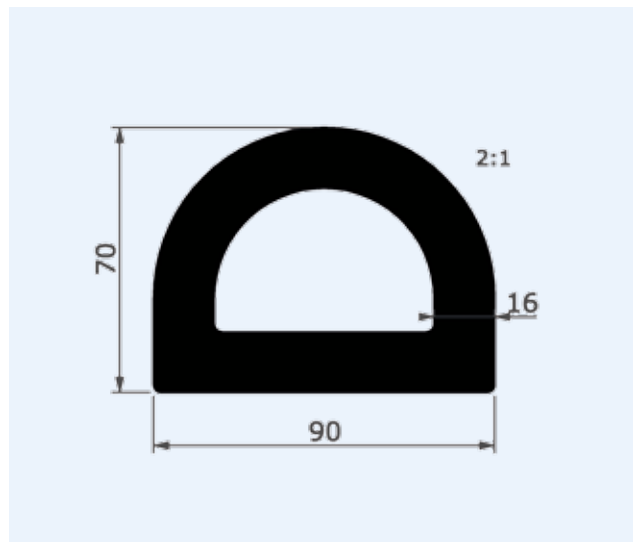

17024

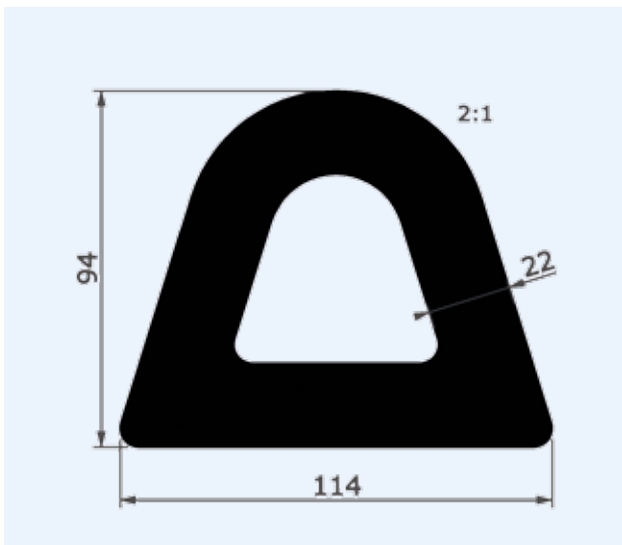

17010

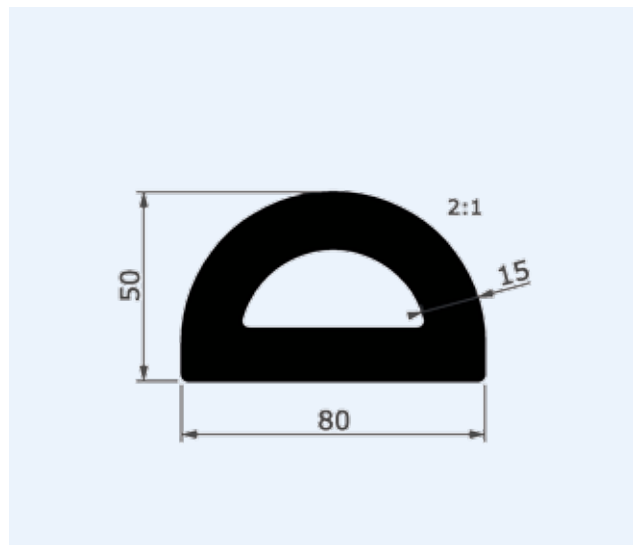

17024L

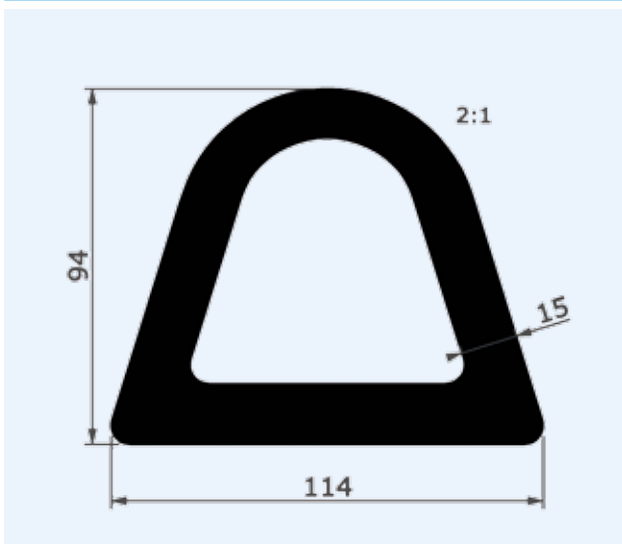

6728

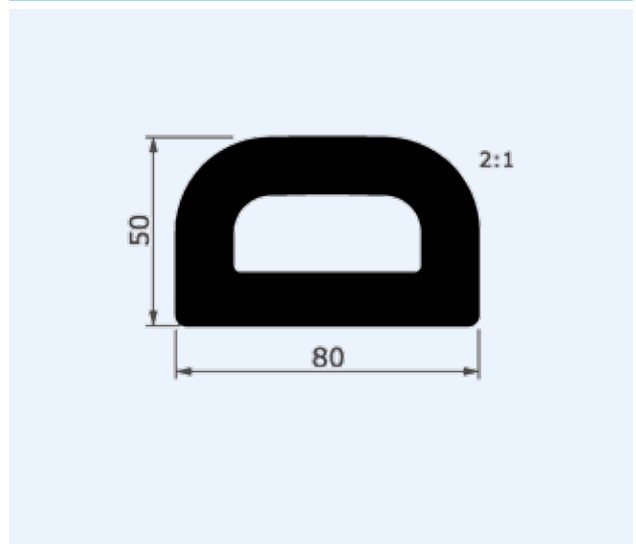

Valkoinen / White

RAL 9016

CMYK	3	0	0	0
RGB	244	251	254	

Beige / Beige

RAL 1001

CMYK	0	20	50	20
RGB	208	172	117	

Harmaa / Grey

RAL 7040

CMYK	20	5	10	40
RGB	134	148	151	

Ruskea / Brown

RAL 8004

CMYK	40	80	80	10
RGB	151	77	65	

Tummanruskea / Dark Brown

RAL 8011

CMYK	10	60	100	80
RGB	76	36	0	

Musta / Black

RAL 9017

CMYK	100	90	100	95
RGB	0	0	0	

Materiaalit

OT-Kumi Oy on kokenut ja osaava tiivistevalmistaja. Yhtiö ja sen henkilökunta on sitoutunut kehitykseen. Seuraamme eri tiivistemateriaaleista ja -profiileista saatuja käyttökokemuksia. Niihin perustamme tuotekehityksemme – se on meille jatkuvaa ja jokapäiväistä toimintaa.

Tuotantolinjamme ovat uudenaikaisia ja tehokkaita. Laadun ja mittatarkkuuden takaamiseksi valmistamme itse profiilien suulakkeet.

TPE eli termoplastiset elastomeerit ovat uusia, edistyskellisiä ja kierrätyskelpoisia raaka-aineita. Niissä yhdistyvät vulkanoidun kumin ja lämpömuovautuvan kestopuovin ominaisuudet.

TPE-materiaali tarjoaa runsaasti mahdollisuuksia tuotesuunnitteluun. TPE-vakiovärimme ovat valkoinen, beige, ruskea, harmaa ja musta – toimitamme tilauksesta myös muita värejä. Tuotteet voidaan valmistaa myös eri kovuusasteisiin.

Elastomeerit kestävät hyvin kemikaaleja lukuunottamatta orgaanisia liuottimia ja aromaattisia öljyjä. Ne kestävät hyvin myös UV-säteilyä ja otsonia. Kylmän sietokyky on –50 celsiusastetta ja kuumun 130 astetta. Silikonikumi on käyttöominaisuuksiltaan ylivoimainen. Se toimii pakkasessa jäykistymättä –50 celsiusasteeseen saakka ja kestää kuumuutta 300 asteeseen.

Silikonin palautumiskyky on erinomainen. Silikoni kestää kosteutta, painetta, höyryä, erilaisia kemikaaleja ja monia öljyjä. Silikoni sietää myös auringonvaloa, otsonia ja sillä on hyvä sähköneristyskyky.

EPDM ja NBR ovat raaka-aineita, joista on vuosien käyttökokemukset ja -tieto. Niistä valmistamme kestäviä, taipuisia ja kimmoisia profiileita. EPDM on yleisin kumi-laatu tiivisteisiin. Sitä on saatavana myös pehmeämpänä solukumina. NBR-nitriilikumi kestää myös öljyä ja vielä vaativampiin olosuhteisiin on kehitetty Elarin-kumi.

Materials

OT-Kumi Oy is an experienced, skilled manufacturer of sealing profiles. The company and its personnel are committed to development. We monitor the experiences gained from the use of different sealing materials and profiles, because they form the cornerstone of our constant, daily product development work.

Our production lines are modern and effective. To ensure high quality and preciseness, we make all profile nozzles ourselves.

TPE, or thermoplastic elastomers are advanced, recyclable raw materials. They combine the properties of vulcanised rubber and thermoplastics. TPE is an easily workable material that gives a plenty of product design opportunities. TPE standard colours are white, beige, brown grey and black, and other colours are also available from order. The profiles are also available in different hardnesses.

Elastomers are highly resistant to chemicals except for organic solvents and aromatic oils. They are also well capable of withstanding UV radiation and ozone. Their cold resistance is –50 degrees and heat resistance 130 degrees.

The properties of silicone rubber are unrivalled. It withstands frost down to –50 degrees without stiffening and heat up to 300 degrees. Silicone is a rubber-like material so its resilience is excellent. It withstands moist, pressure, vapour, chemicals, many oil types, resists sunlight and ozone, and has good electrical insulation properties.

EPDM and NBR are widely used, tried and tested raw materials that have been utilised for years. We use them to make durable, flexible, elastic profiles.

EPDM is most common material for sealing profiles. It is also available as softer cellular rubber version. Nitrile-rubber (NBR) is excellent choice, when oil touches profiles. Elarin-rubber is material for very demanding conditions.

Poikkileikkausmittojen toleranssit

Diameter tolerances

Perusmitta		Luokka			
Basic		Classification			
measurement		E1	E2	E3	E4
mm	mm	±mm	±mm	±mm	±mm
0	- ≤ 2,5	0,20	0,35	0,50	0,80
2,5	- ≤ 4,0	0,25	0,40	0,70	1,00
4,0	- ≤ 6,3	0,35	0,50	0,80	1,30
6,3	- ≤ 10	0,40	0,70	1,00	1,60
10	- ≤ 16	0,50	0,80	1,30	2,00
16	- ≤ 25	0,70	1,00	1,60	2,50
25	- ≤ 40	0,80	1,30	2,00	3,20
40	- ≤ 63	-	1,60	2,50	4,00
63	- ≤ 100	-	2,00	3,20	5,00

Katkaistujen pituuksien toleranssit

Cut length tolerances

Perusmitta		Luokka			
Basic		Classification			
measurement		L1	L2	L3	L4
mm	mm	±mm	±mm	±mm	±mm
0	- ≤ 40	0,7	1,0	1,6	3,2
40	- ≤ 63	0,8	1,3	2,0	4,0
63	- ≤ 100	1,0	1,6	2,5	5,0
100	- ≤ 160	1,3	2,0	3,2	6,3
160	- ≤ 250	1,6	2,5	4,0	10,0
250	- ≤ 400	2,0	3,2	5,0	12,5
400	- ≤ 630	2,5	4,0	6,3	16,0
630	- ≤ 1000	3,2	5,0	10,0	20,0
1000	- ≤ 1600	4,0	6,3	12,5	25,0
1600	- ≤ 2500	5,0	10,0	16,0	32,0
2500	- ≤ 4000	6,3	12,5	20,0	40,0
	< 4000	±0,16%	±0,32%	±0,5%	±1,0%

Solukumiivisteet / Cellular rubber strips

Poikkileikkausmittojen toleranssit

Diameter tolerances

Perusmitta		Luokka		
Basic		Classification		
measurement		E1	E2	E3
mm	mm	±mm	±mm	±mm
0	- ≤ 2,5	0,35	0,50	0,80
2,5	- ≤ 4	0,40	0,70	1,00
4,0	- ≤ 6,3	0,50	0,80	1,30
6,3	- ≤ 10	0,70	1,00	1,60
10	- ≤ 16	0,80	1,30	2,00
16	- ≤ 25	1,00	1,60	2,50
25	- ≤ 40	1,30	2,00	3,20
40	- ≤ 63	1,60	2,50	4,00
63	- ≤ 100	2,00	3,20	5,00

Katkaistujen pituuksien toleranssit

Cut length tolerances

Perusmitta		Luokka		
Basic		Classification		
measurement		L1	L2	L3
mm	mm	±mm	±mm	±mm
0	- ≤ 40	1,0	1,6	3,2
40	- ≤ 63	1,3	2,0	4,0
63	- ≤ 100	1,6	2,5	5,0
100	- ≤ 160	2,0	3,2	6,3
160	- ≤ 250	2,5	4,0	10,0
250	- ≤ 400	3,2	5,0	12,5
400	- ≤ 630	4,0	6,3	16,0
630	- ≤ 1000	5,0	10,0	20,0
1000	- ≤ 1600	6,3	12,5	25,0
1600	- ≤ 2500	10,0	16,0	32,0
2500	- ≤ 4000	12,5	20,0	40,0
	< 4000	±0,32%	±0,50%	±1,00%

Kumituotteiden toleranssit

Toleranssitaulukot ovat standardin SFS 3558 mukaisia. Saman tuotteen eri mittoihin voidaan soveltaa eri toleranssi- luokkia. Kumi laajenee tullessaan suulakkeen läpi ja vulkanoinnissa tavallisesti muuttaa muotoaan ja kutistuu. Laajeneman ja kutistuman suuruusluokka riippuu kumityypistä sekä sekoituksen laadusta. Pehmeästä kumista valmistetut tuotteet vaativat väljemmät toleranssit kuin kovemmat kumilaadut.

Rubber product's tolerances

Tolerance tables are according to the standards SFS 3558. Different tolerance guides can be applied to products with varying measurements. Extruded rubber expands as it passes through the die and after vulcanization it changes shape and shrinks. The expansion and shrinkage factors depend upon the rubber type and the quality of the mixture. Products made from soft rubber require greater tolerances than those made from harder qualities.



OT-Kumi Oy

Ota yhteyttä

Lieksentie 8
91100 Ii
p. 08 655 8800
fax 08 817 4123
myynti@ot-kumi.com

Contact Us

Lieksentie 8
91100 Ii, Finland
tel. +358 8 655 8800
fax +358 8 817 4123
sales@ot-kumi.com

www.ot-kumi.com

